

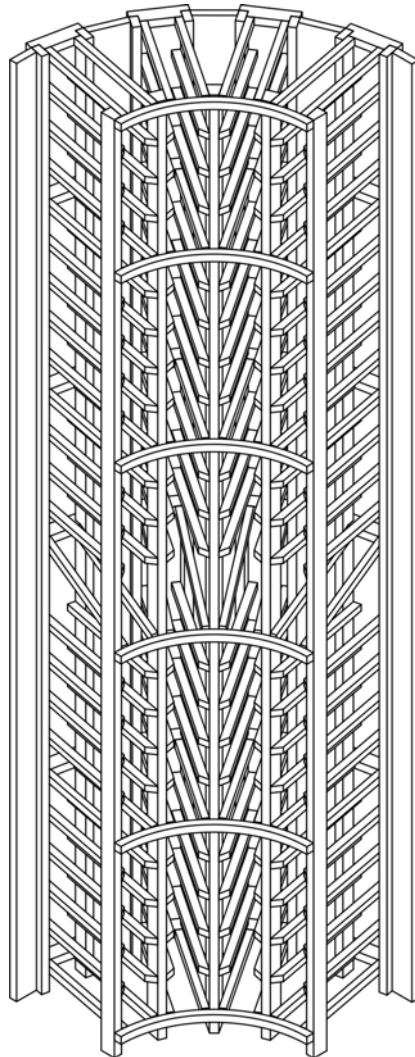

Mahogany Wine Rack Assembly Instructions

Curved Corner



Congratulations! You have purchased the finest wine racking available anywhere. Properly assembled, these solid mahogany Vigilant wine racks will outlast even your finest wines. Please call toll free **888-812-4427** if you have any questions or problems.

Tools Required for Assembly:

- Electric drill or cordless screw gun
- 9/64" drill bit
- Phillips Head Screwdriver
- #2 Square drive bit
- Hammer, preferably rubber or soft-faced

Note: If you have chosen your wine rack to be finished without pre-drilled holes, you will need a pneumatic nail gun to properly assemble your rack

Parts List:

Before starting, carefully review the parts and quantities against the parts list to make sure you have everything you need. Then read through the instructions, taking time to familiarize yourself with the components and steps.

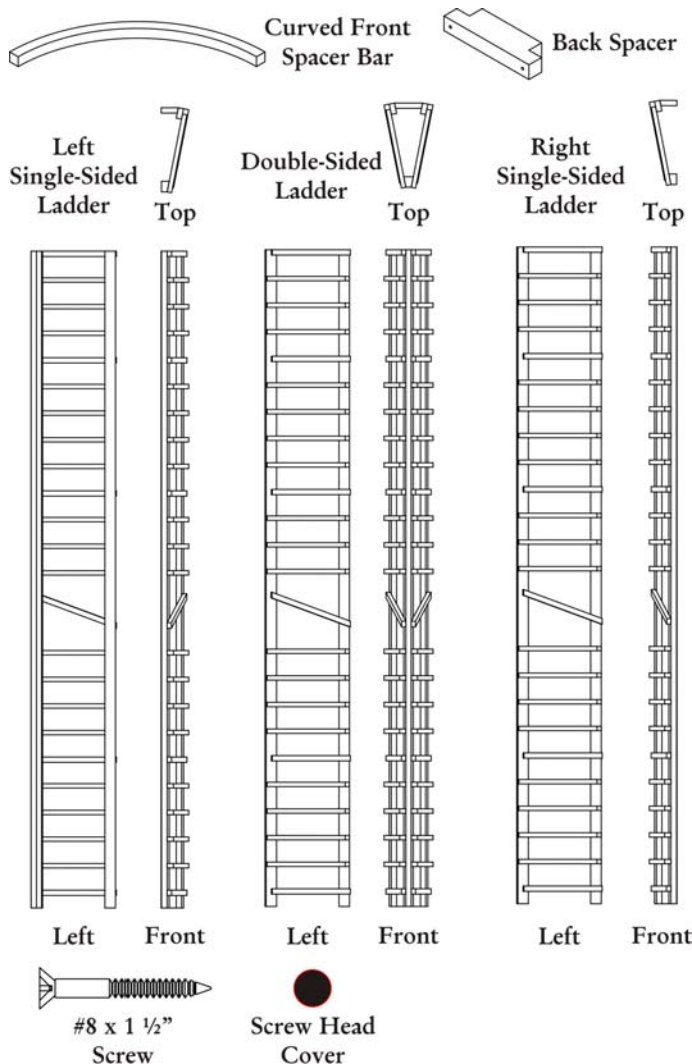

- Classic Series (77 1/2" high)**
- 2 Single-Sided Ladders (77 1/2" long)
 - 3 Double-Sided Ladders (77 1/2" long)
 - 65 #8 Square Head Screws (1 1/2" long)
 - 25 Screw Head Caps
 - 5 Curved Front Spacer Bars
 - 19 Back Spacer Bars
 - 1 Stain Stick (for stain racks only)

- Estate Series (92 1/2" high)**
- 2 Single-Sided Ladders (92 1/2" long)
 - 3 Double-Sided Ladders (92 1/2" long)
 - 78 #8 Square Head Screws (1 1/2" long)
 - 30 Screw Head Caps
 - 6 Curved Front Spacer Bars
 - 24 Back Spacer Bars
 - 1 Stain Stick (for stain racks only)

Parts List

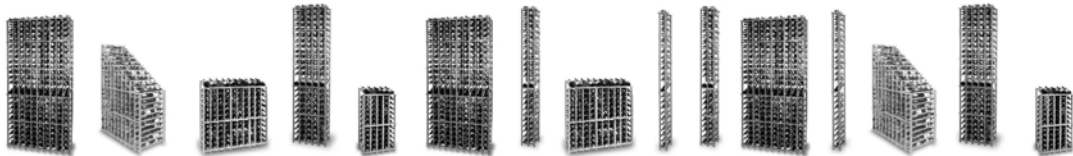

Tips: For Building Your Wine Racks

Before assembling your rack, line up all of your spacer bars. If any spacer bars have blemishes from shipping they can be used as back spacer bars, where they will not be seen.

If you are using a powered screw gun that has a clutch, make sure to set it at a low setting first until you find the right setting. If you have it set high it may over tighten and then split the wood.

Pre-drill all screw holes with a 9/64" drill bit. This makes it less likely for your wood to split. (The easiest way to do this is to follow the pre-drilled holes provided on certain pieces as your guide.)

When you screw through the spacer bar and into the ladder upright do not over tighten, especially on the end locations. Over tightening can cause your spacer bar to split.

Make sure you align the top of your spacer bar to the top of the spacer slat.

When drilling your rack into the wall it is easiest to drill through your top back spacer bar and into the wall stud.

When attaching racking to adjacent racking we recommend using clamps to hold the adjacent racks together before securing with screws.

The best placement for your screws, to secure adjacent racks is under all spacer bar locations. This keeps the screws hidden and keeps your rack secure and steady.

How to Care for Your Stained & Lacquered Wine Racks

Your Vigilant wine racks are built using the highest quality mahogany wood and finish available. When properly cared for, your wine racks will last longer than your finest bottles of wine. Here are a few tips on maintaining the quality and consistency of your racking.

Remove Dust: Dust build up from small airborne particles may scratch the surface if not removed correctly. Simply wipe the surface with a cloth dampened with a cleaning polish or mild detergent.

Clean: Fingerprints, cooking fumes, smoking residue, etc., accumulate on any surface. None of these contaminants will harm our Clear Guard™ finish, but they should be periodically removed to restore the finish to its original luster. Just wipe the surface with a cloth dampened with a non-wax containing polish or mild detergent solution. Avoid the use of ammonia based products or silicone oil, as they may cause damage if used over a long period of time.

Our Clear Guard™ finish is durable and resistant to most household spills. However, spills should be wiped up promptly to avoid potential problems.

Excessive prolonged exposure to direct sunlight, high temperatures and high humidity can cause damage to both the finish and the wood itself. These should be avoided.

Following these simple steps will keep your finished wine racks looking like new for many years.

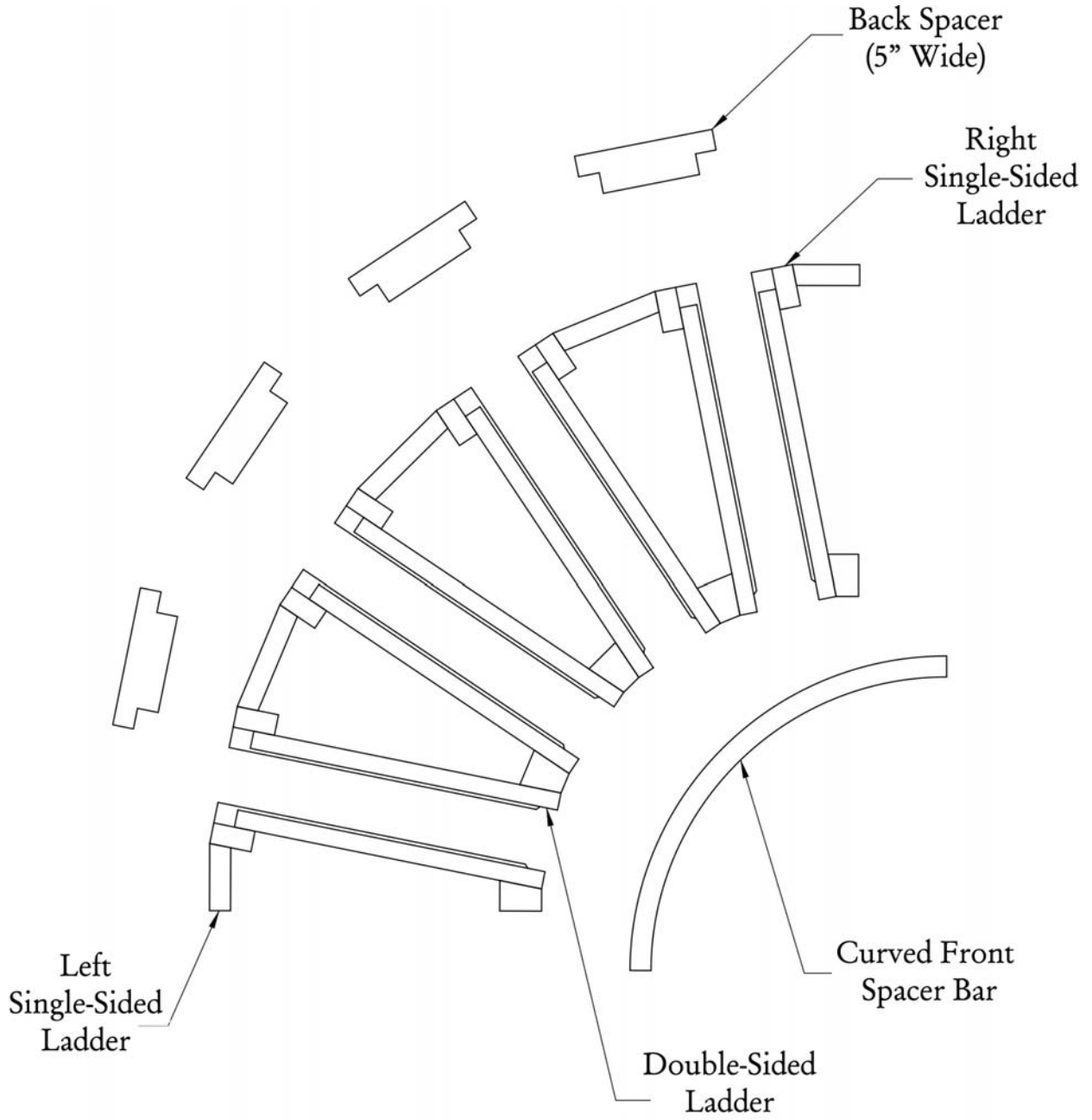
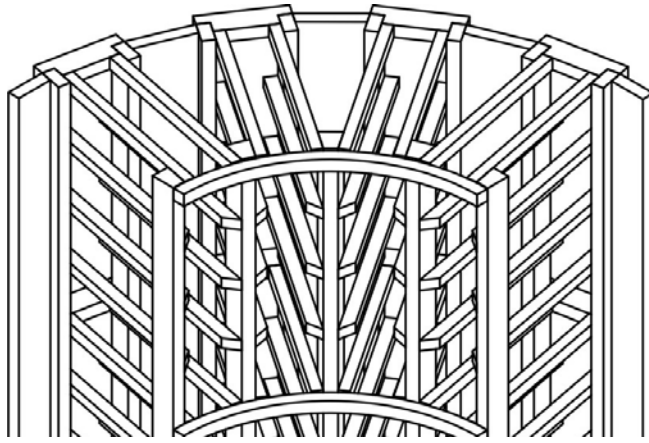

Overhead Exploded View

Steps to Assembly

Please see notes in instructions for special steps on assembling racking without screws.

1. Locate the right single-sided ladder and a doubled-sided ladder. You will notice that the top of the ladder has horizontal slats flush with the top of the uprights, while the bottom slats are set in $1\frac{3}{4}$ " from the bottom of the uprights. The ladder fronts are distinguished by slats that have an angled face, while the backs show the square ends of the horizontal slats (**See Parts List**). Stand these two ladders upright so that the slats are facing inward toward each other (**Figure 1**).

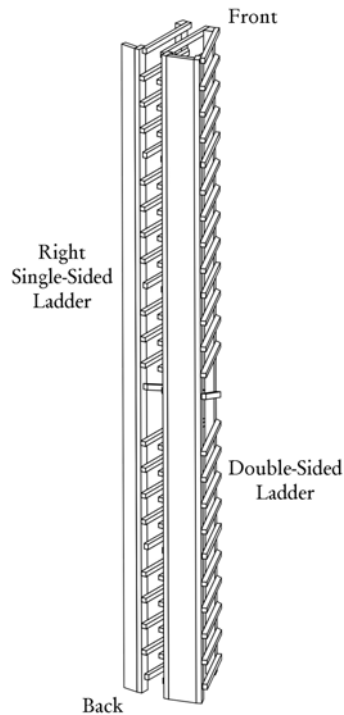

Figure 1

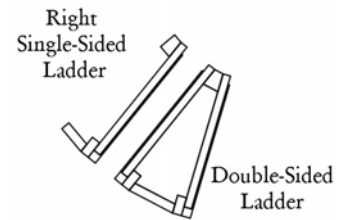

Figure 1 (Overhead View)

2. Locate the first back spacer. In the middle spacer position, pre-drill through the spacer and into the uprights on each side. Attach using two square head screws provided (**Figure 2**).

Note: If you are not pre-drilling the curved corner rack, Vigilant recommends that you screw the back spacer bars for added security.

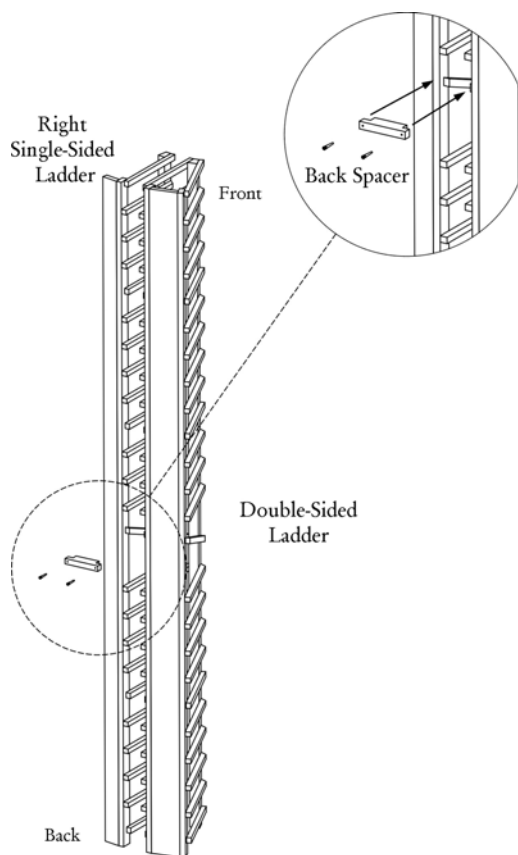

Figure 2

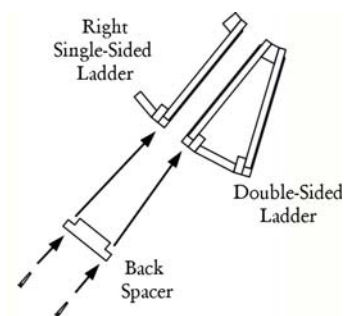

Figure 2 (Overhead View)

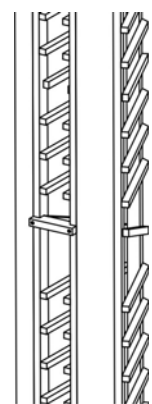

Figure 2 (Complete)

3. Repeat step 2 for the three back spacers above and the two below the one attached (**Figure 3**). (Note: There will only be two above for Classic height racks)

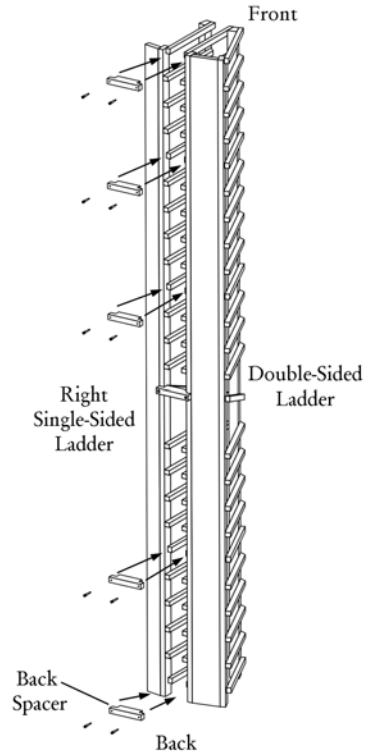

Figure 3

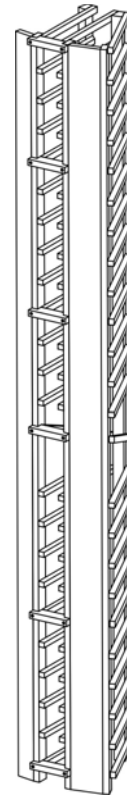

Figure 3 (Complete)

4. Locate the second double-sided ladder and place it beside the first. Be sure to position the angled slats facing forward.

5. Starting at the top spacer location, pre-drill through the back spacers and into each upright. Attach using two square head screws provided (**Figure 4**).

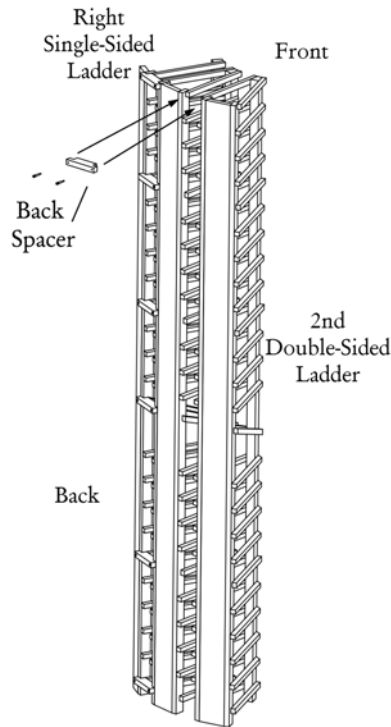

Figure 4

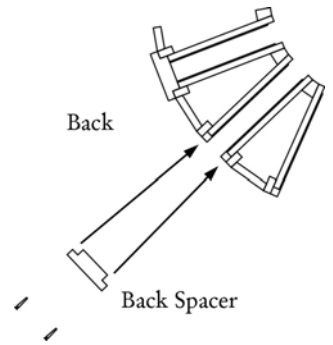

Figure 4 (Overhead View)

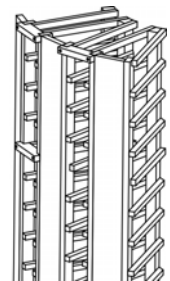

Figure 4 (Complete)

6. Repeat for the five remaining back spacer bars (**Figure 5**) starting at the top and ending at the bottom. (Note: there will be four back spacers for Classic height racks)

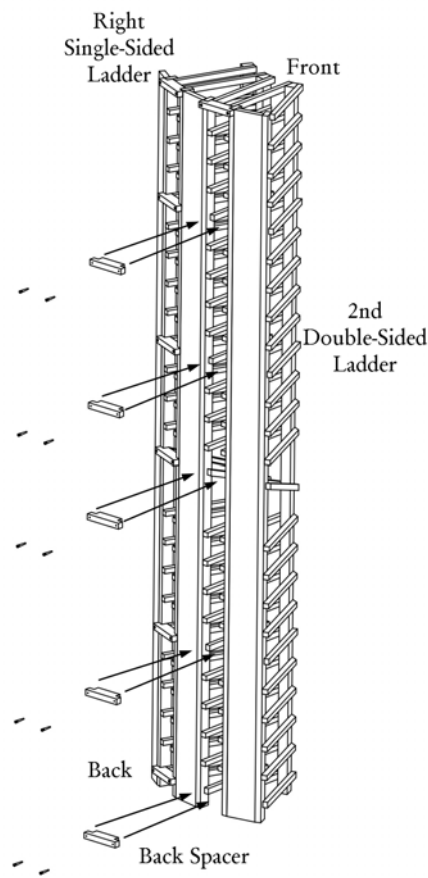

Figure 5

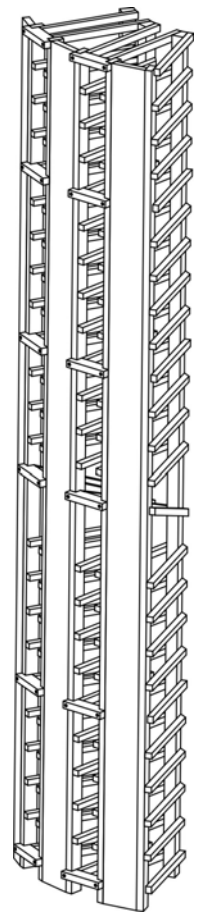

Figure 5
(Complete)

7. Repeat steps 4 thru 6 for the third double-sided ladder (**Figure 6**).

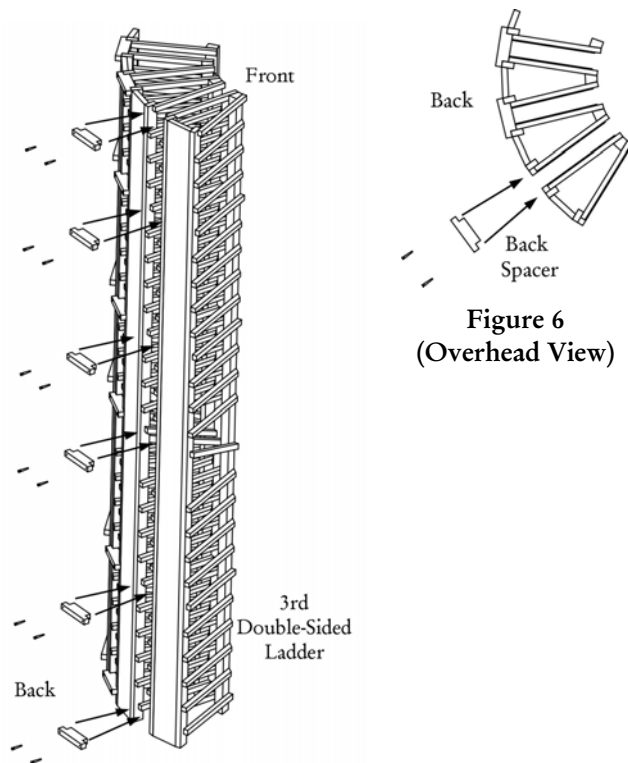

Figure 6

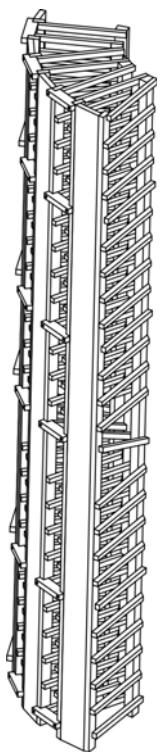

Figure 6
(Complete)

8. Locate your left single-sided ladder and align it with the last double-sided ladder with the slats facing each other. Repeat steps 5 and 6 to attach (Figure 7).

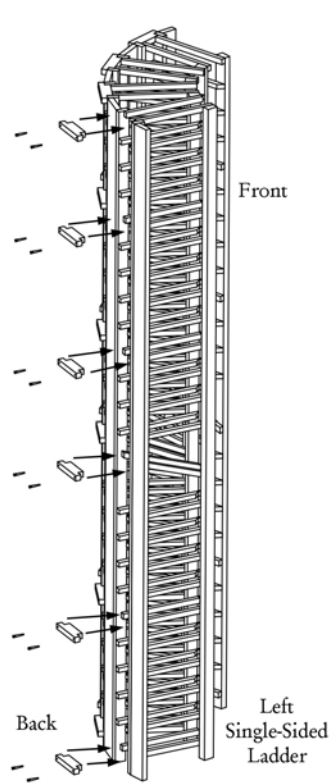

Figure 7

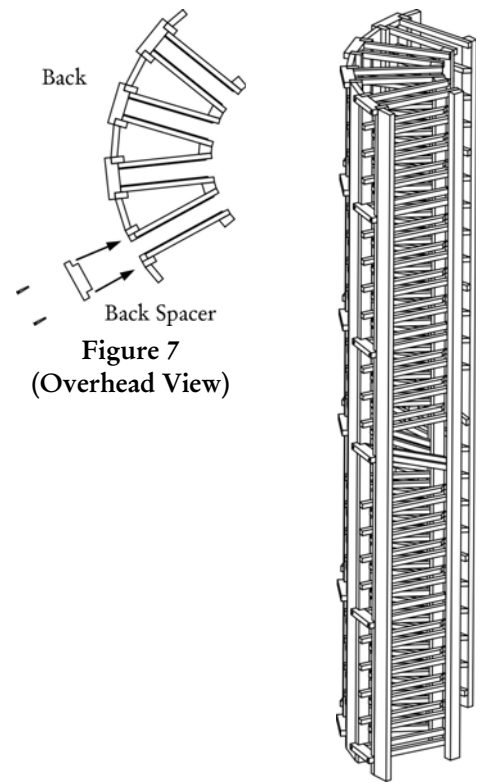

Figure 7
(Complete)

9. The back of the curved corner rack should now be complete (Figure 8).

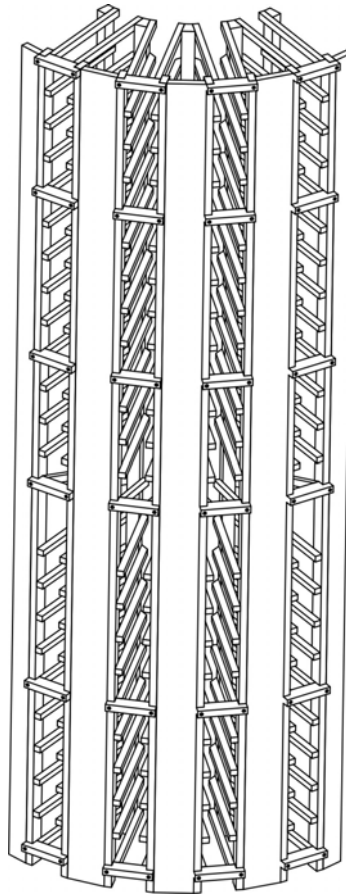

Figure 8

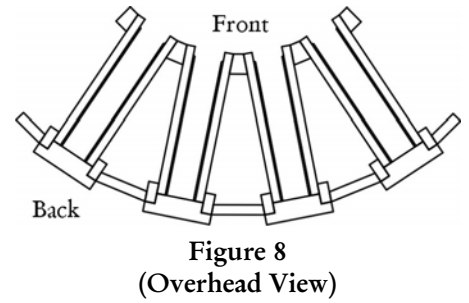

Figure 8
(Overhead View)

10. Locate the two extra back spacers. Place them, (DO NOT pre-drill or attach), above the bottom spacer bar location at the far left and far right columns (**Figure 9**).

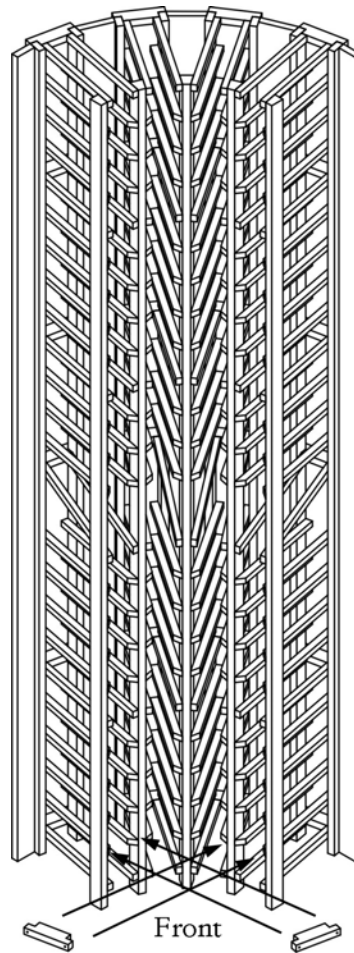

Figure 9

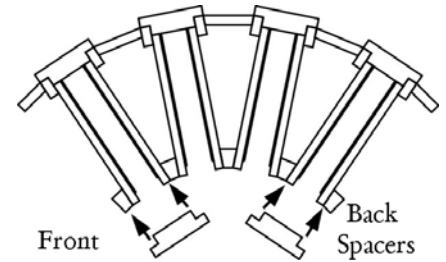

Figure 9 (Overhead View)

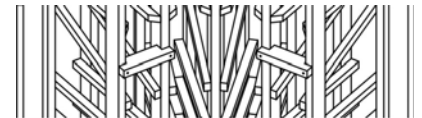

Figure 9 (Complete)

11. You will find that your curved front spacer bars have been supplied to you in lengths that exceed what is needed for the front of the wine rack. This has been done so that the front spacer bar matches up to the curve at all five front ladder locations (**See Figure 10**). Slide your front spacer bar along the front of the ladders until it meets flush with all five ladder fronts (**See Figure 10 Overhead View**). This is where you will attach your spacer bar.

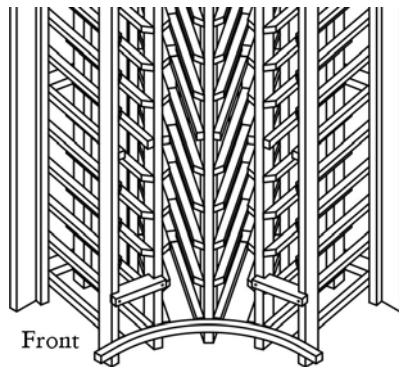

Figure 10

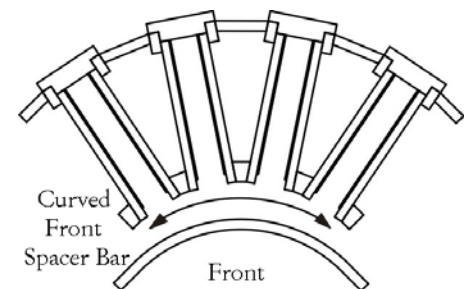

Figure 10 (Overhead View)

Still holding the spacer bar in place, adjust the center double-sided ladder to so that the bottle opening on the two end columns is $3\frac{1}{2}$ " wide and the opening for the center columns is $3\frac{7}{16}$ " wide (**Figure 10 Complete View**).

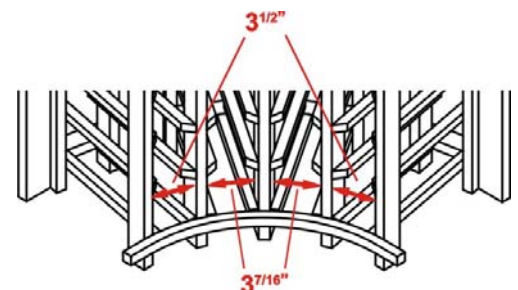

Figure 10 (Complete)

12. Once the curved front spacer bar is positioned correctly, mark each end. Take the first front spacer bar and cut in the location you marked (**Figure 11 Cut Lines**).

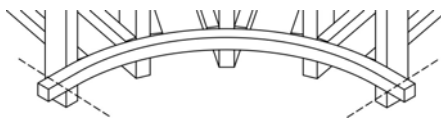

Figure 11 (Cut Lines)

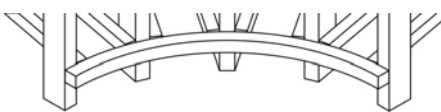

Figure 11 (Completed)

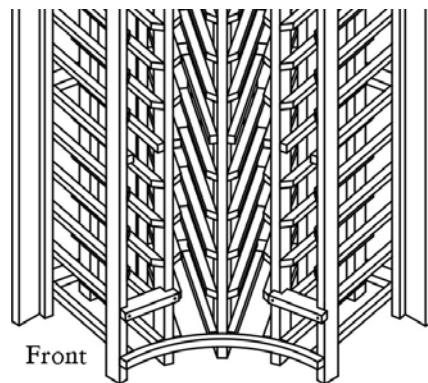

Figure 11

13. Place the cut spacer bar in the bottom front spacer location and pre-drill through the spacer bar and into each upright. Remove the back spacers you placed in step 10 and attach the front spacer bar using five of the square head screws provided (**Figure 12**).

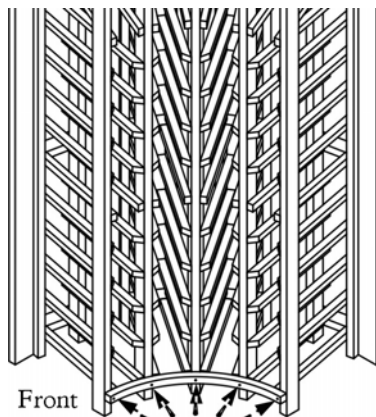

Figure 12

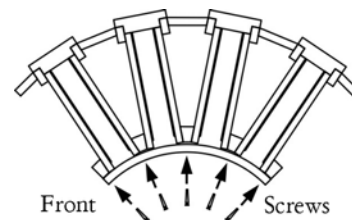

Figure 12 (Overhead View)

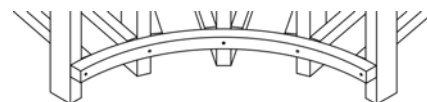

Figure 12 (Completed)

Note: if you are not pre-drilling and are nailing the curved front spacer bars to the rack, it is strongly recommended to use a nail gun and attach at each upright position.

14. Repeat steps 11 thru 14 for the remaining curved front spacer bars.

15. Your rack is now complete and ready to be positioned in its final location.

16. If this rack is being used as a stand alone wine rack it is recommended to attach to the wall using L-brackets (not provided). Attach each L-bracket to the top back spacers and then to the wall. If this rack is attached to adjacent racking, be sure that the adjacent racking is secured to the wall.

****Failure to attach the rack to the wall or adjacent rack could result in the rack tipping over. When fully loaded with wine your rack will weigh 240lbs. for the Classic Series and 300lbs. for the Estate Series.**

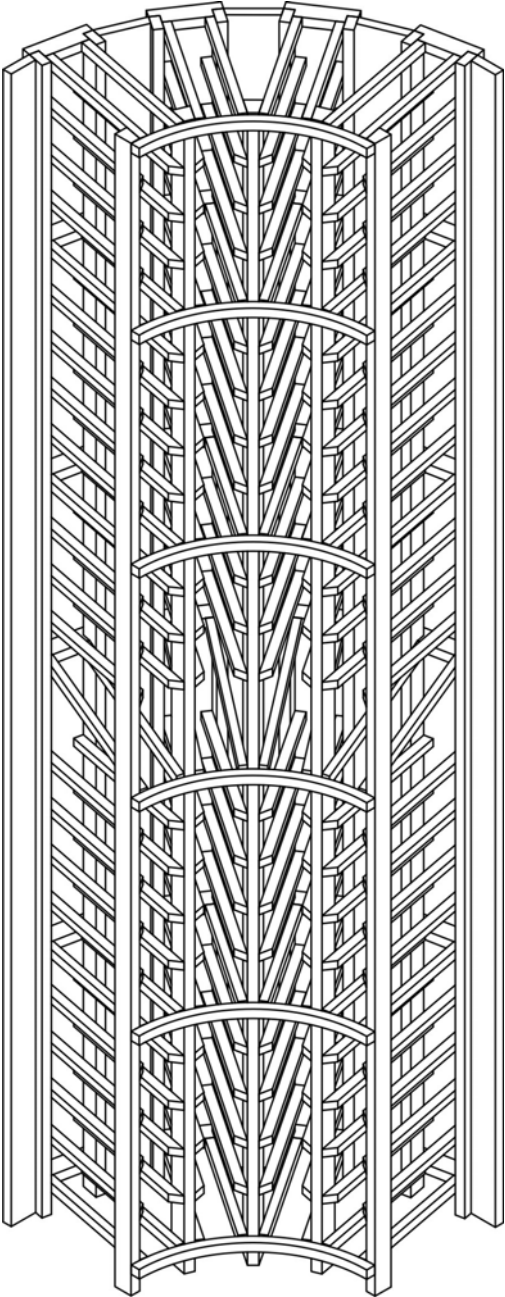

Additional installation questions?
Contact us:



VIGILANT, INC.
85 Industrial Park Drive
Dover, NH 03820
Toll Free 1-888-812-4427
Outside US 1-603-285-0400
Fax 1-603-285-0420
email: info@vigilantinc.com
On the web www.vigilantinc.com