



Commercial Wine & Liquor Display

Double Displays



Congratulations! You have purchased a superior commercial wine rack kit. These commercial kits have been specifically designed to properly store and display your wine. Please call toll free 888.812.4427 if you have any questions or problems.

Tools Required:

- Philips Head Screw Driver
- Power Drill
- 1/8" Drill Bit
- Counter Sink
- Mallet

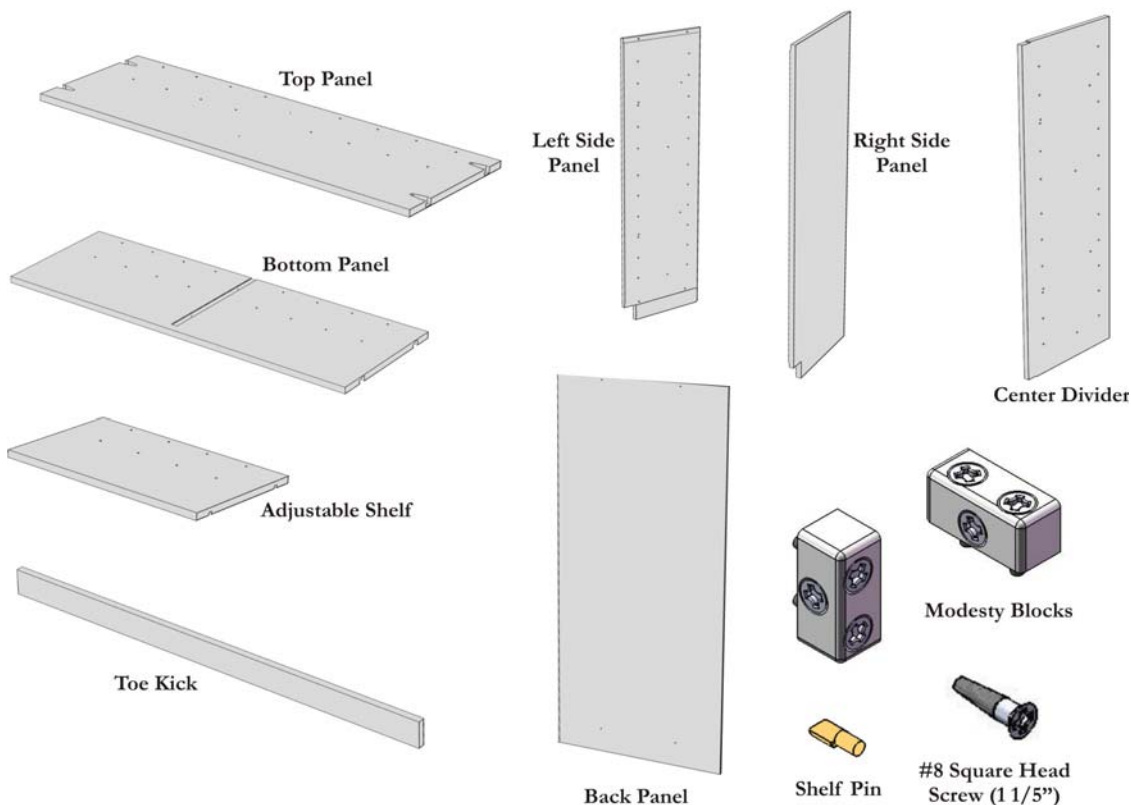

Parts

- (1) Top Panel
- (4) Adjustable Shelves
- (1) Bottom Panel
- (1) Left Side Panel
- (1) Right Side Panel
- (1) Center Divider
- (2) Back Panels
- (12) #8 x 1 1/4" Square Head Screws
- (16) Shelf Pins
- (1) Toe Kick
- (3) Modesty Blocks
- (9) #8 x 1" Square Head Screws
- (12) Connector Studs

Parts List

**Please note that on a top cabinet the Left and Right Panel will not have the base indentation. The parts list will exclude the Toe Kick, Modesty Blocks, and #8 x 1" Square Head Screws.

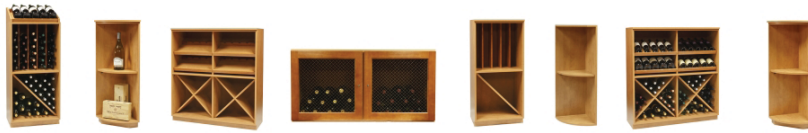

Commercial Wine Rack Tips

Do not use a power drill when tightening your CAM fittings, if you do your CAM fitting could break.

Do not over tighten your CAM fittings or the CAM fitting will break.

Before assembling your commercial wine storage unit place a blanket down. You want a clean and scratch free surface during assembly.

Pre-drill all screw holes with a 1/8" drill bit. This makes it less likely for your wood to split. (The easiest way to do this is to follow the pre-drilled holes provided on certain pieces as your guide.)

If you are assembling a quarter round, **Do Not** pre-drill your screws holes for the toe kick or you might drill through the bottom shelf.

When assembling your case work make sure that all front edges are flush to one another.

Exploded View

Note: Exploded view of Base Cabinet shown. Top Cabinet is the same excluding the toe kick assembly.

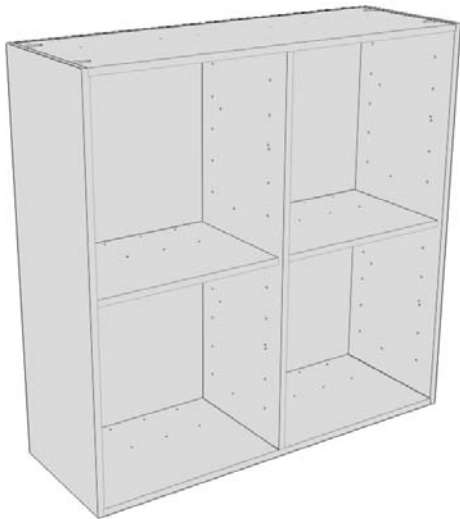
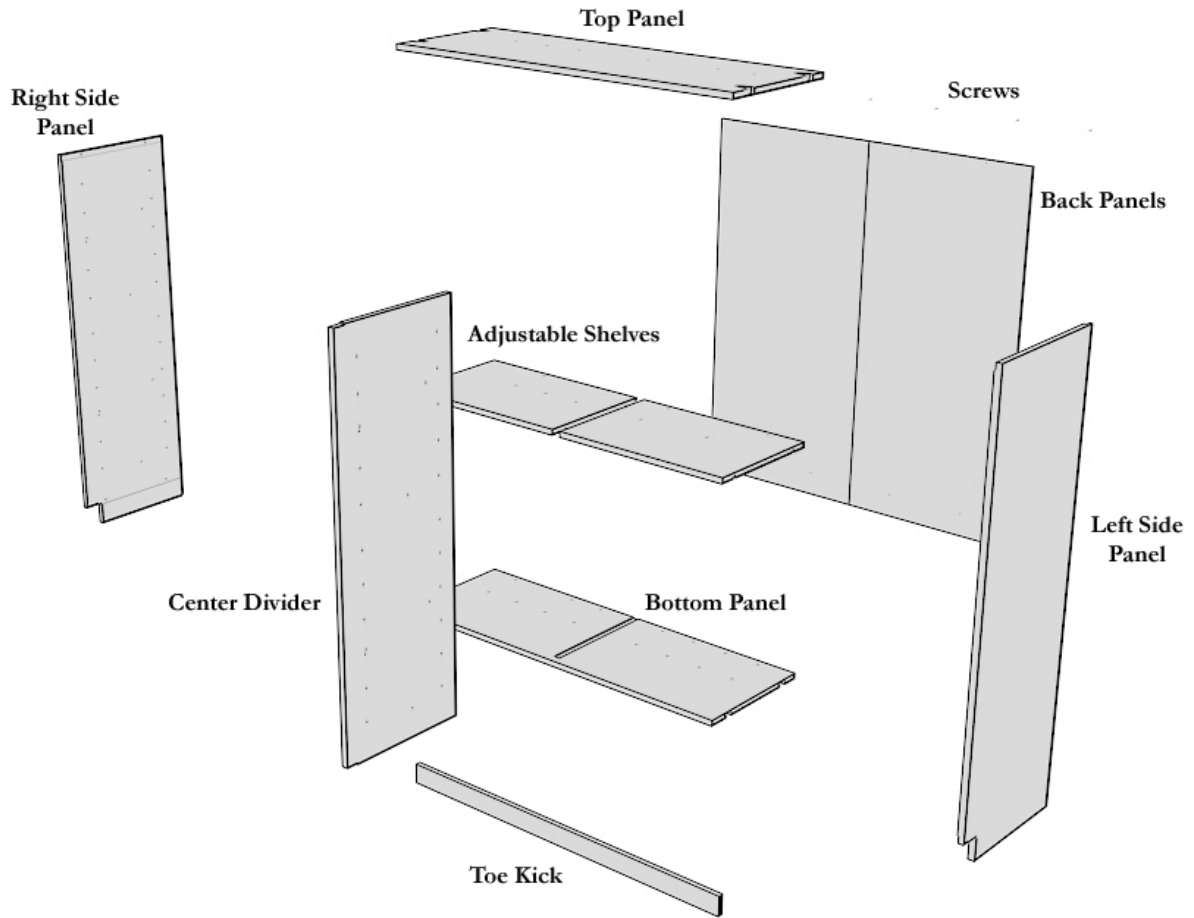

Double Top Cabinet

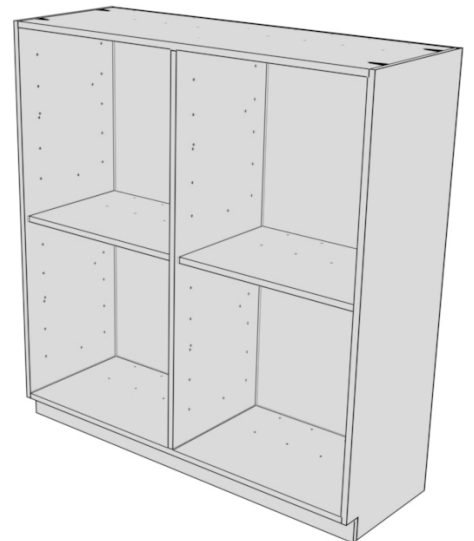

Double Base Cabinet

Steps to Assembly

Step 1

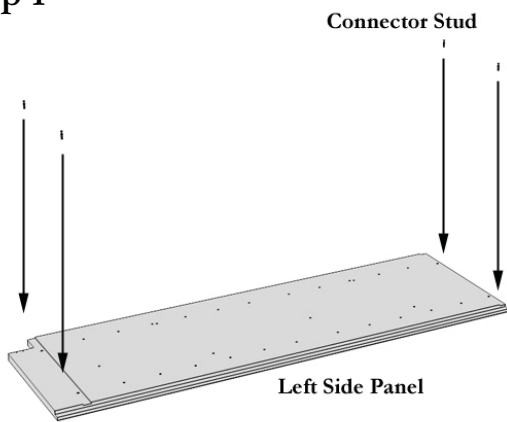

Find the 6 connector stud holes on the right and left side panels and insert the connector studs.

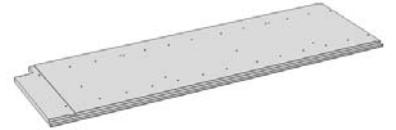

Step 2

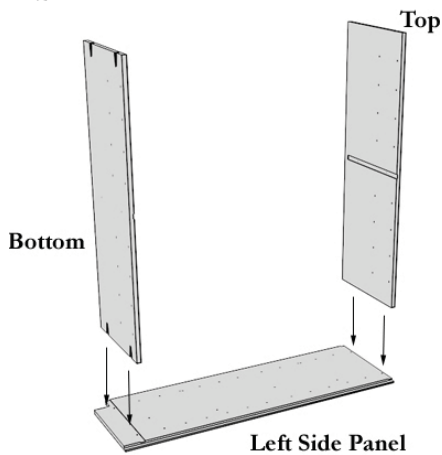

Set the bottom and top panel into the dadoes (or grooves) on the bottom, and top of the left side panel. Tighten the CAM fitting around the connector stud by turning clockwise 90 degrees.

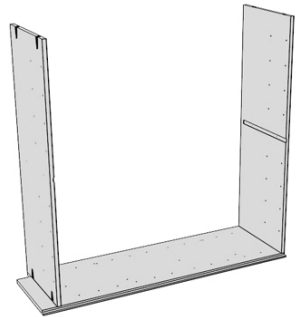

Step 3

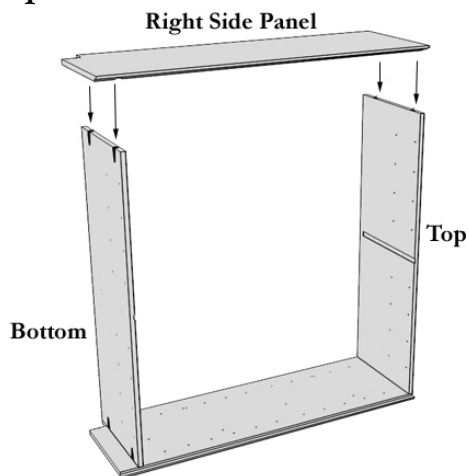

Locate the right side panel, aligning the CAM fittings with the connector studs on the top and bottom. Tighten all the CAM fittings around the connector studs.

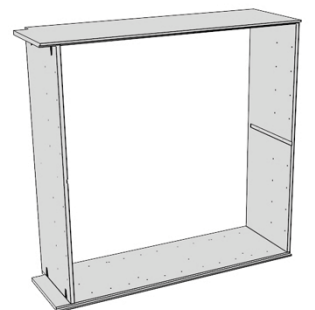

Step 4

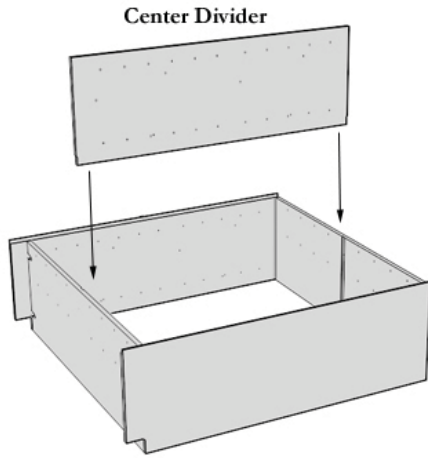

Flip the assembly so that the front of the cabinet faces the floor. Locate the center divider. Slide into the dados (or grooves) on the top panel and bottom panel.

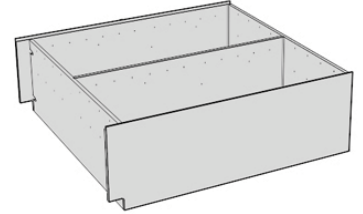

Step 5

Connector Studs

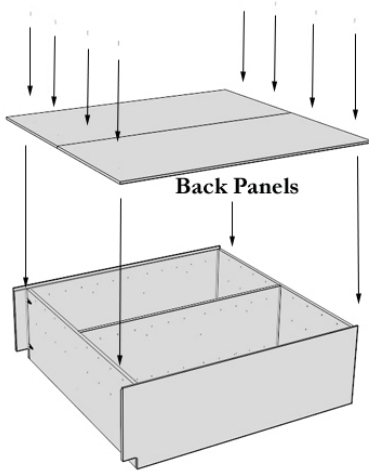

Locate the back panels. Slide in from the bottom until the tops of the (2) back panels are flush with the top of the cabinet. Using the existing holes on the back panels, pre-drill into the cabinet. Attach using #8 x 1 1/4" screws provided.

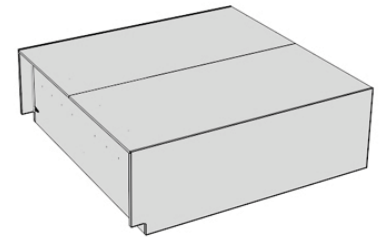

Note: Skip Step 6 and proceed to Step 7 if building a top cabinet.

Step 6

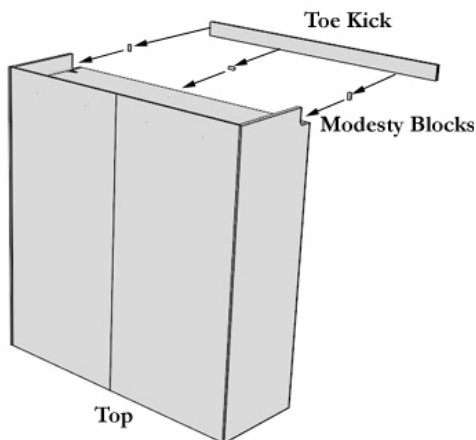

Flip the cabinet so the top is facing down. Locate the three modesty blocks. Attach one to the right side panel edge and the other to the left side panel edge using (2) #8 x 1" screws provided for each modesty block. Line the third modesty block up to the pre-drilled holes on the bottom panel. Attach using (2) #8 x 1" screws provided. Place the toe kick in front of the modesty blocks and attach with the remaining #8 x 1" screws provided.

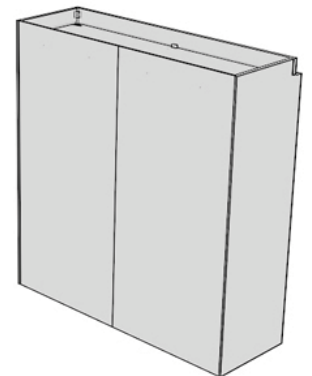

Step 7

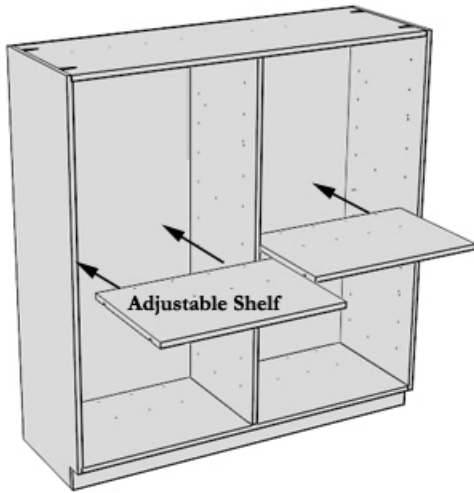

Insert shelf pins provided in the center hole location. Insert the adjustable shelf into the cabinet making sure it rests level.

Note: If the cabinet is being used for wine display inserts, place shelf pins on the 6th pin hole down.

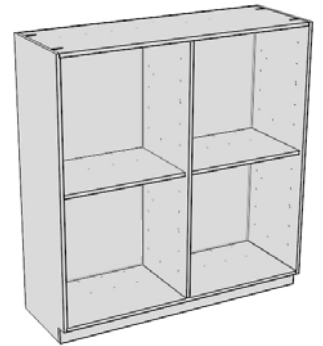

Optional Tabletop

*For base cabinet only

*Tabletop sold separately

Tools Required:

-Power Drill -1/8" Drill Bit

Parts:

(1)Tabletop (4)#8 x 1 1/4" Square Head Screws

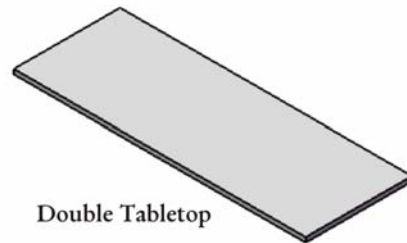

#8 Square Head Screw (1 1/4")

Step 1

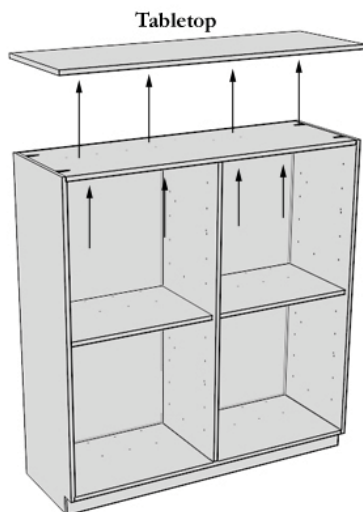

Place the tabletop over the cabinet. Make sure that the tabletop is flush with both the sides and the back before attaching. (**Note: the tabletop should hang 3/4" over the front of the cabinet**) Using the holes on the top panel of the cabinet, attach the tabletop using the #8 x 1 1/4" square head screws provided.

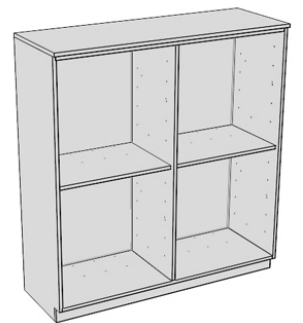

Optional Inserts (Shown with Single Base Display)

Half Diamond

*No Assembly Required

Parts:

(1) Half Diamond Panel

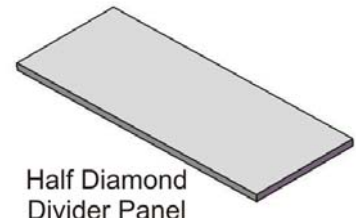

Step 1

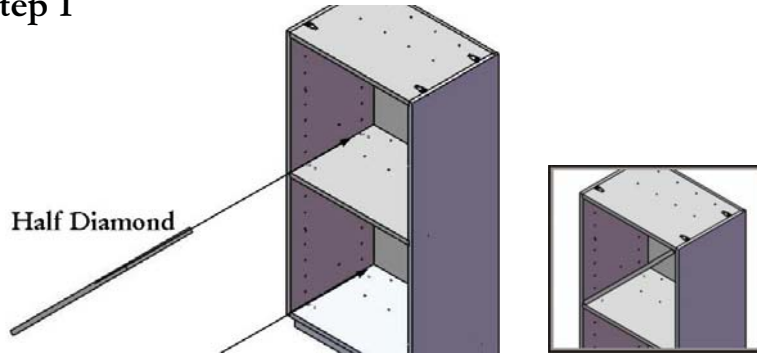

Angle the half diamond panel so that it slides into the cabinet from corner to corner. Make sure that the finished edge is flush and facing forward.

Diamond Divider

Parts:

(1) Front Panel

(1) Back Panel

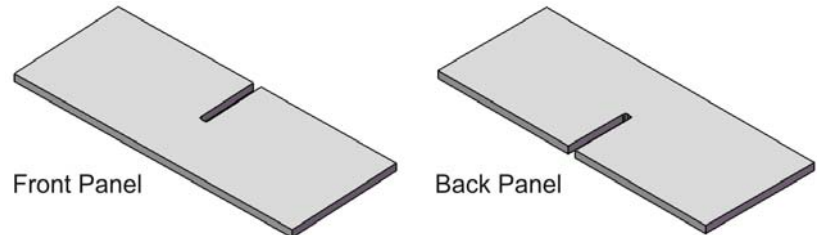

Step 1

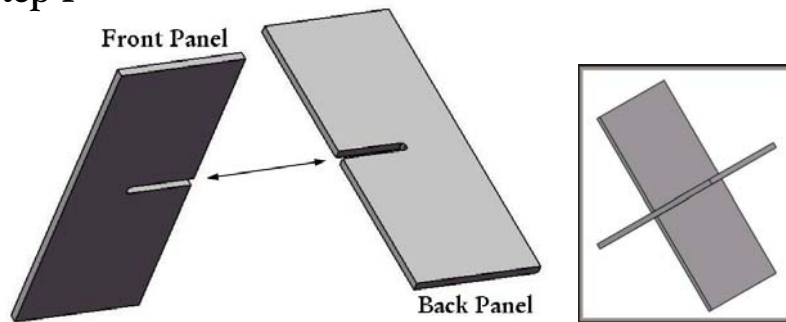

Insert front panel into the back panel at roughly a 45 degree angle. The slots on each panel should fit directly over each other. Make sure that the finished edges are flush and facing forward.

Step 2

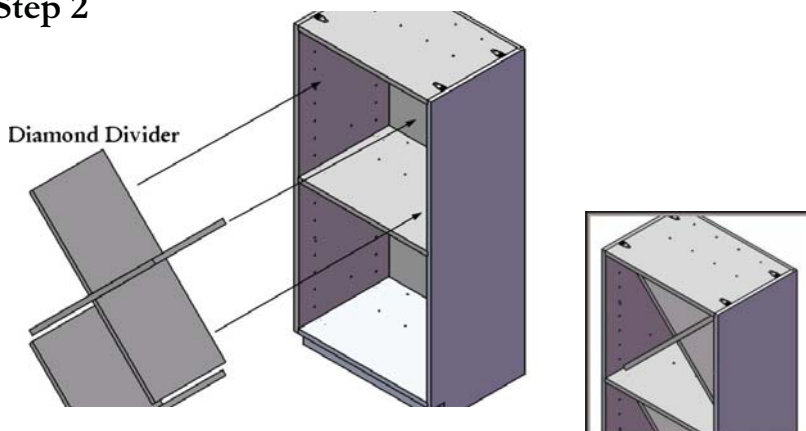

The diamond divider is now complete and can be inserted into the cabinet.

Display Shelf

Tools Required:

-Power Drill -1/8" Drill Bit

Parts:

(1)Bottle Neck Rest (3)#8 Square Head Screws
(1)Shelf Base (4)Shelf Pins

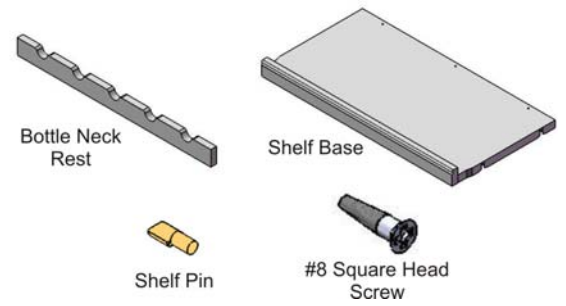

Step 1

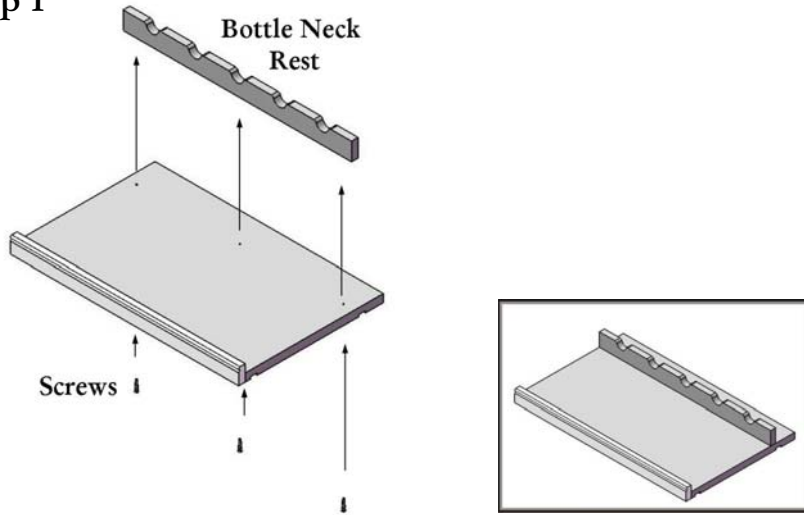

Pre-drill screw holes into the shelf base. Using the screws provided, drill through the holes on the bottom of the shelf base until the tip of the screw is showing. Line the bottle neck rest up with the screws and drill to attach.

Step 2

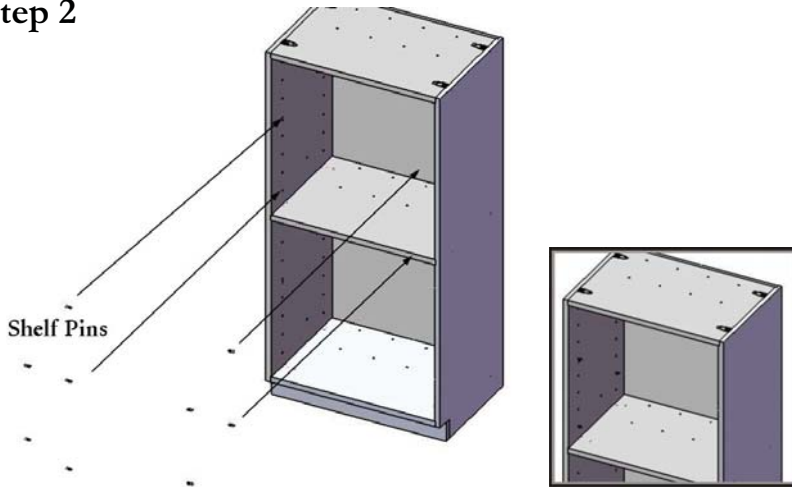

Insert the shelf pins provided into the cabinet to achieve desired shelf resting position.

Step 3

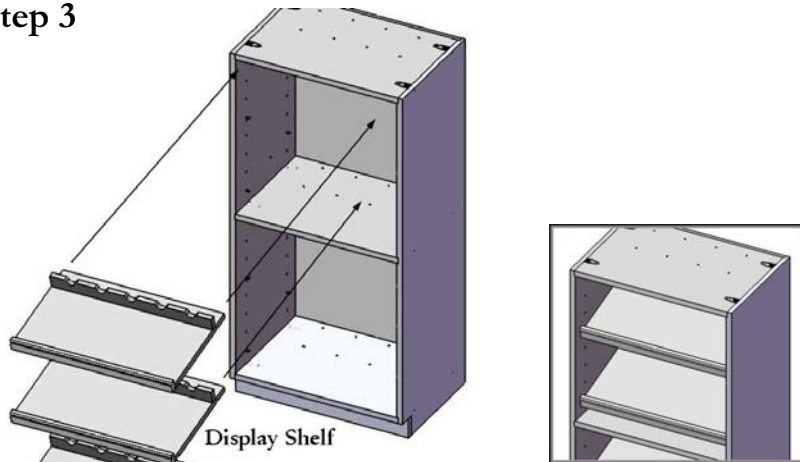

Insert the display shelves into the cabinet. (Display shelves can be inserted level or at a 20 degree angle.)

Flat Shelf

*No Assembly Required

Parts:

(1) Flat Shelf (4) Shelf Pins

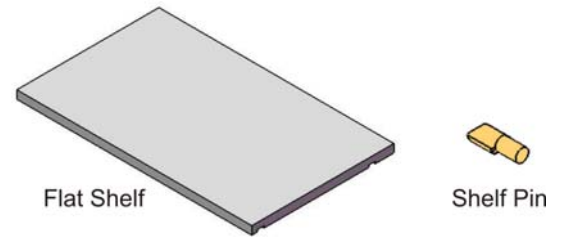

Step 1

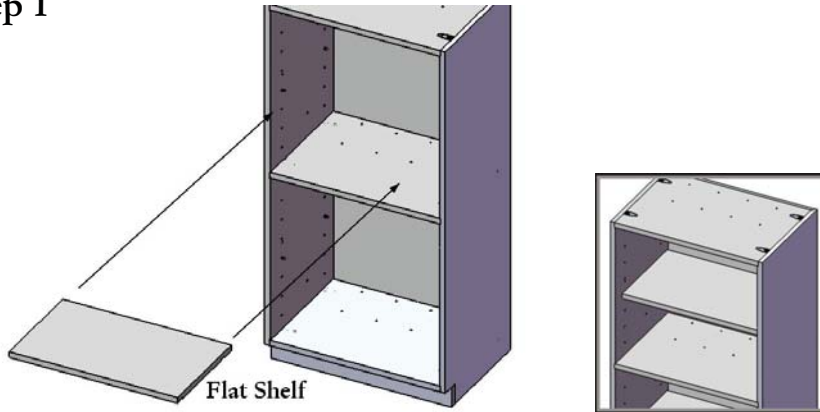

Insert shelf pins provided as done in Step 2 on page 7. Insert the flat shelf into the cabinet making sure it rests level.

Column Dividers

Parts:

(4) Column Dividers (16) Column Pins

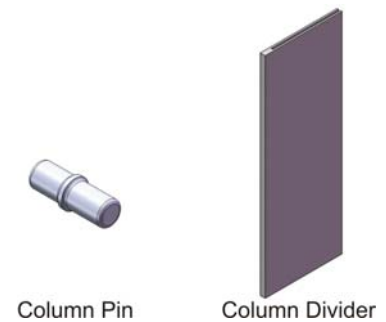

Step 1

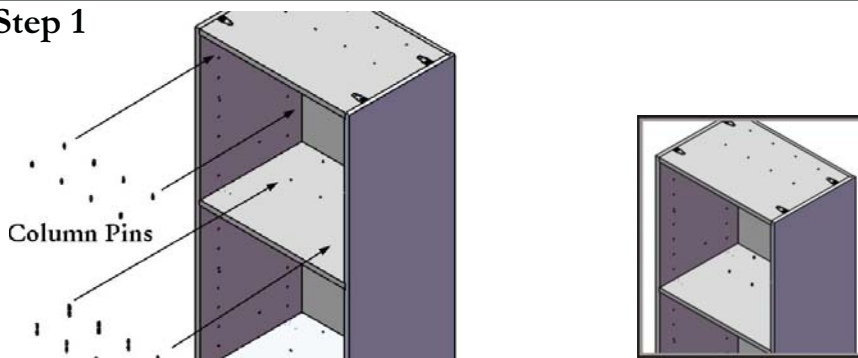

Insert column pins into the top and bottom of each shelf/panel of the cabinet.

Step 2

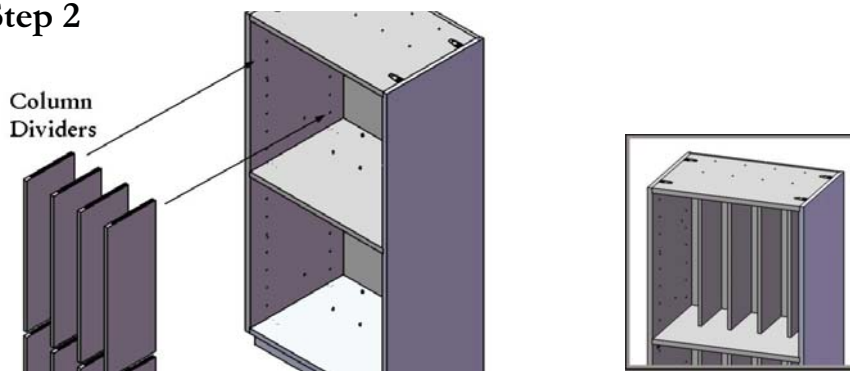

Line the dados, or grooves on the column dividers with the pins in the cabinet and slide into the cabinet.

Column Insert with Slats

Parts:

(1)Divider (10)Slats
(10)Dowels (44)Column Pins

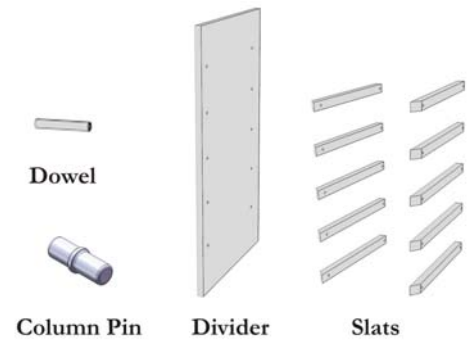

Step 1

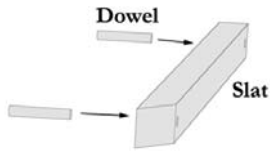

Locate five (5) slats. Insert two (2) dowels into each slat in the pre-drilled holes provided.



Step 2

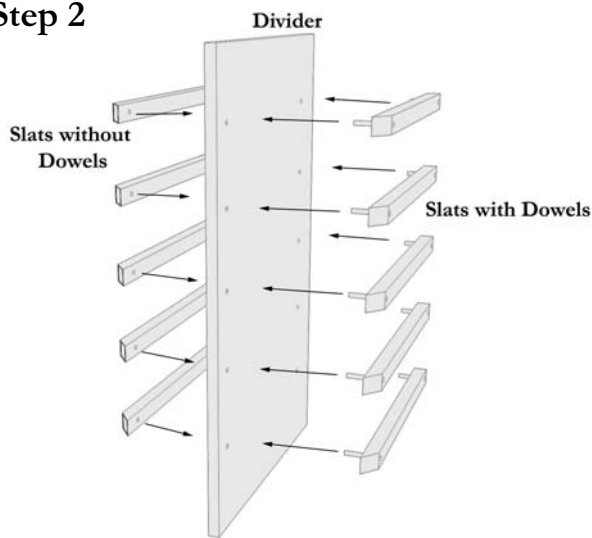

Insert the first slat with dowels into the top dowel hole position on the divider. Repeat for the four (4) remaining doweled slats. Once the first five (5) slats are in place, locate the five (5) slats without dowels. Place these slats over the dowels on the opposite side of the divider.

Note: a mallet may be needed to lightly tap slat in place.

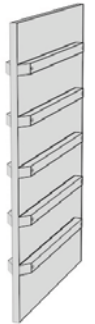

Step 3

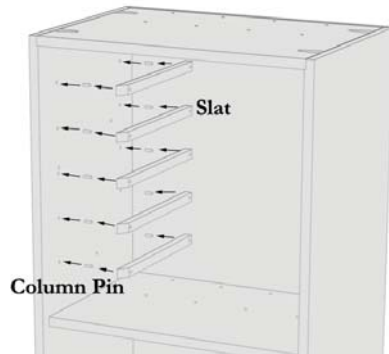

Locate (20) column pins and insert them into the pin holes on each side panel of the cabinet. Place a slat over each set of column pins.



Step 4

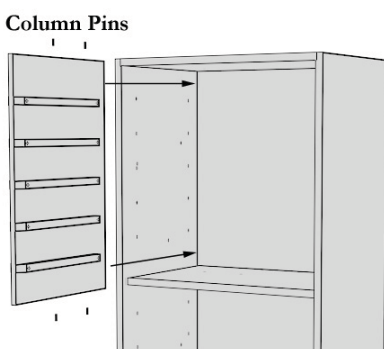

Insert the remaining column pins (6 per column) into the top and shelf panels. Slide a divider over each column pin location. The Column Insert is now complete.



Bin Insert

*For base cabinets only.

Tools Required:

-Power Drill -1/8" Drill Bit

Parts:

- (1) Left Side Panel
- (1) Right Side Panel
- (1) Bottom Panel
- (1) Back Panel
- (1) Top Front Rail
- (1) Middle Front Rail
- (1) Bottom Front Rail
- (6) #8 x 1 1/2" Round Head Washer Screws
- (6) #8 x 1 1/2" Square Head Screws
- (4) Shelf Pins

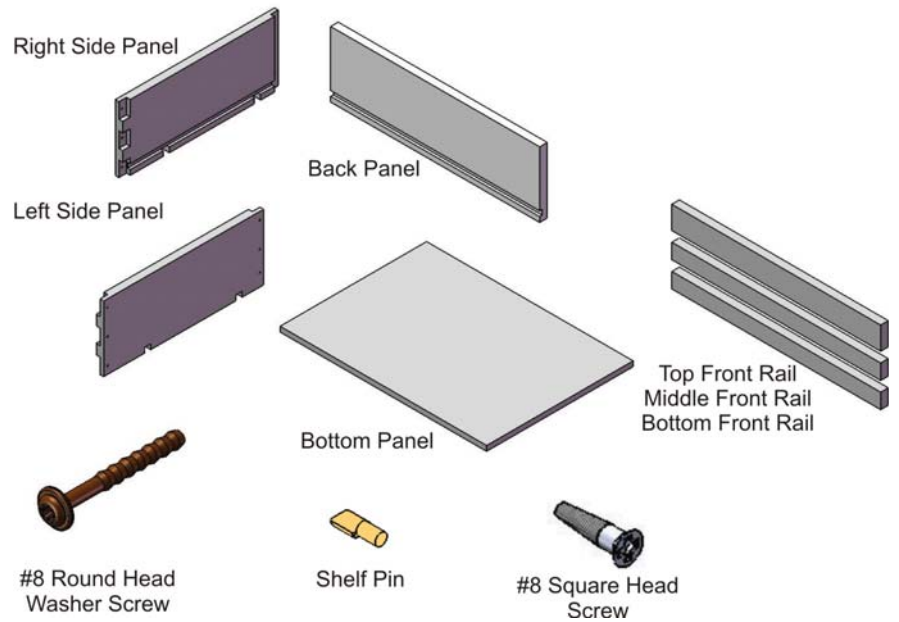

Step 1

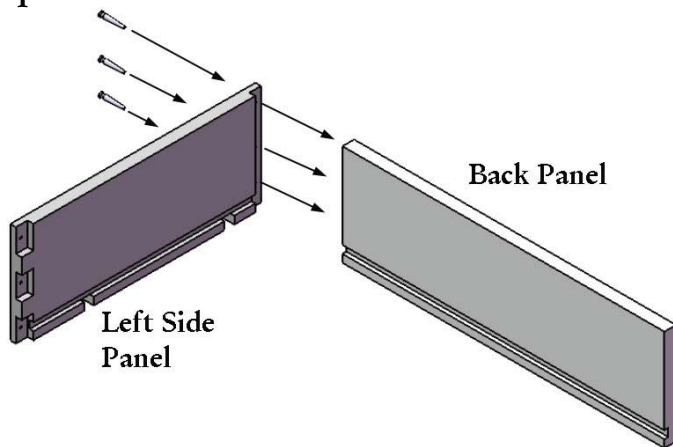

Pre-drill through the holes provided on the left side panel and into the back panel. Attach using (3) 1 1/2" square head screws provided.

Step 2

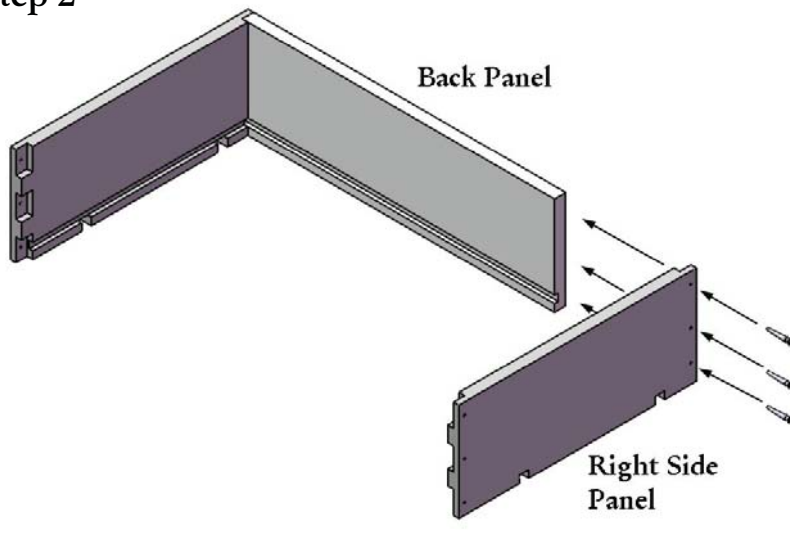

Repeat Step 1 for right side panel.

Step 3

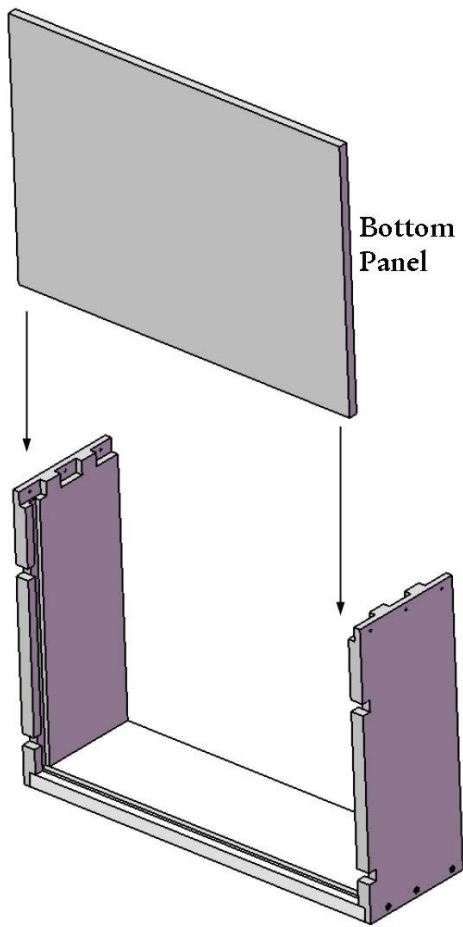

Flip the assembly onto its back and slide the bottom panel into the dados on the right and left side panel. Line up with the dado on the back panel.

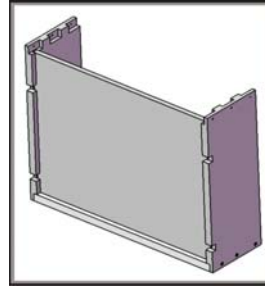

Step 4

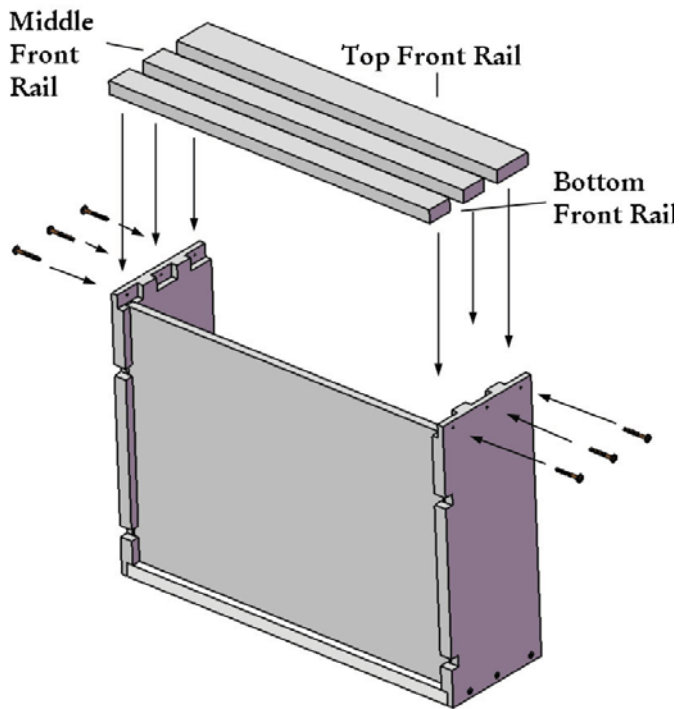

Pre-drill the right and left side panel into the front rails. Attach each rail, starting with the bottom front rail using the 6 round head washer screws provided. (**Note: You may need to use a mallet to tap into place.**)

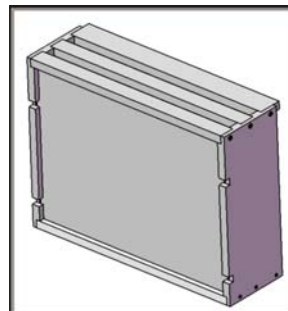

Optional Accessories

Tabletop Display

Tools Required:

- Power Drill -1/8" Drill Bit
- Phillips Head Screw Driver

Parts:

- (1) Base Panel
- (1) Upper Support
- (1) Lower Support
- (1) Bottle Neck Rest
- (1) Right Side
- (1) Left Side
- (8) Connector Studs
- (3) #8 x 1 1/2" Screws

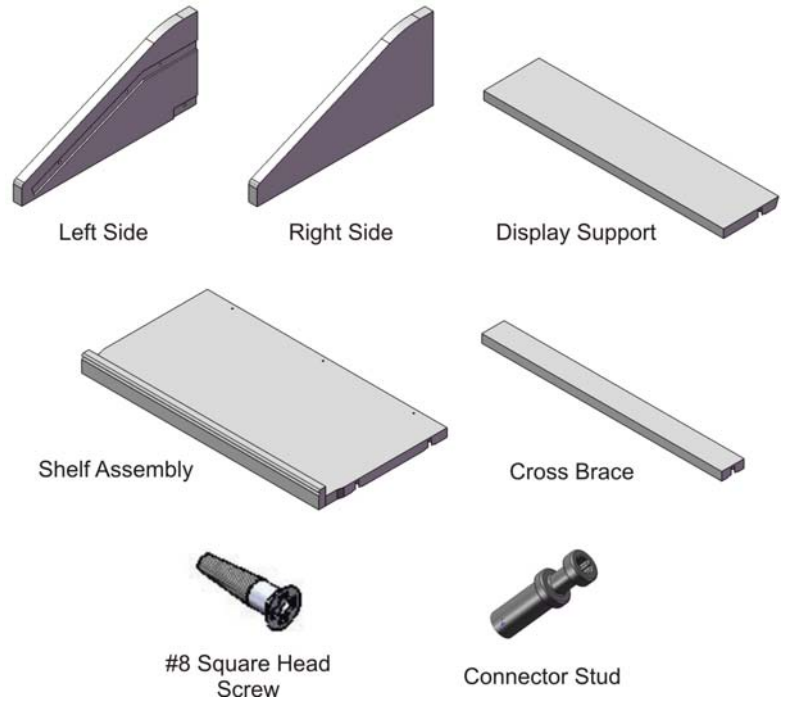

Step 1

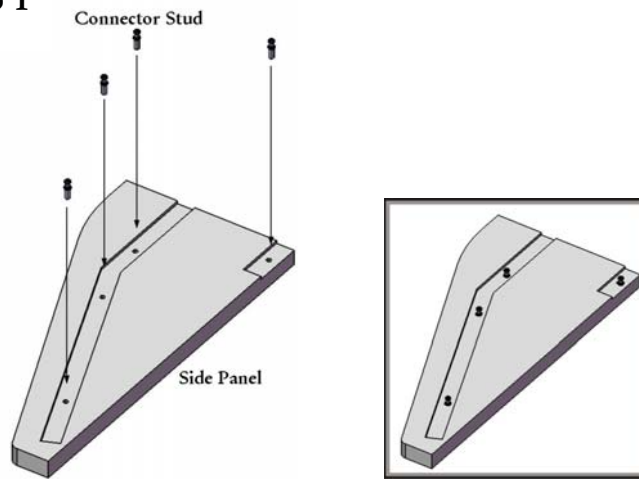

Find the 4 Connector stud holes on the side panels and insert the connector studs.

Step 2

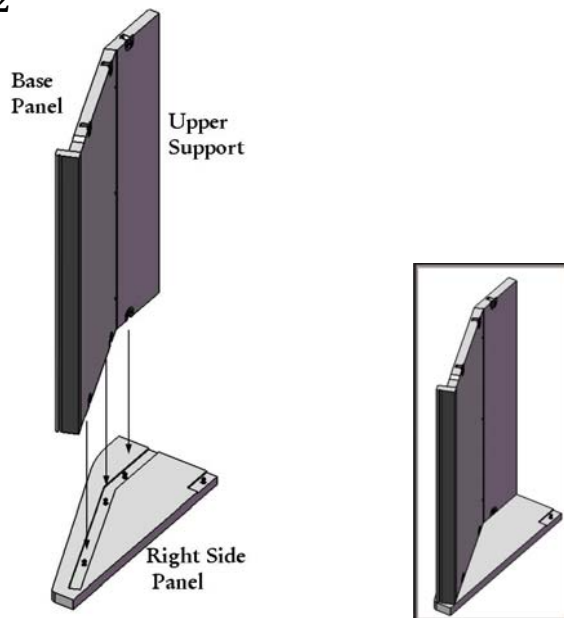

Set your upper support and base panel into the dados (or grooves) on the side panel. Tighten the CAM around the connector stud by turning clockwise 90 degrees.

Step 3

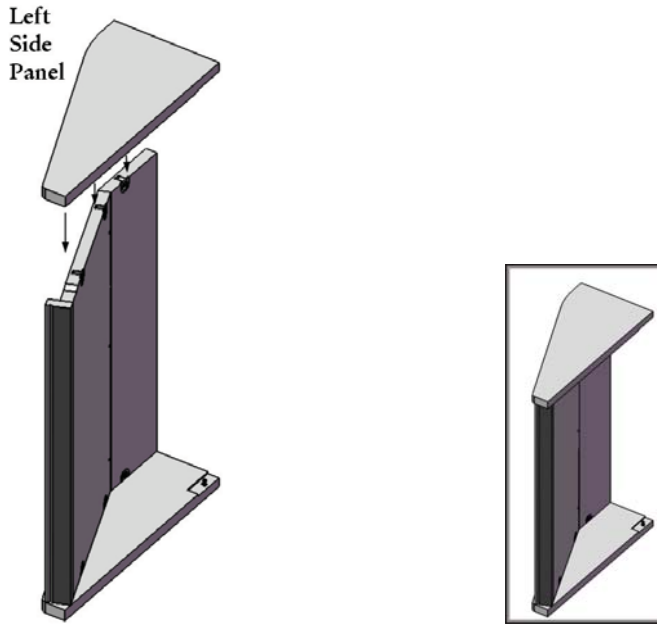

Locate your left side panel, aligning the CAM fittings with the connector studs on the side panel. Tighten all the CAM fittings around the connector studs.

Step 4

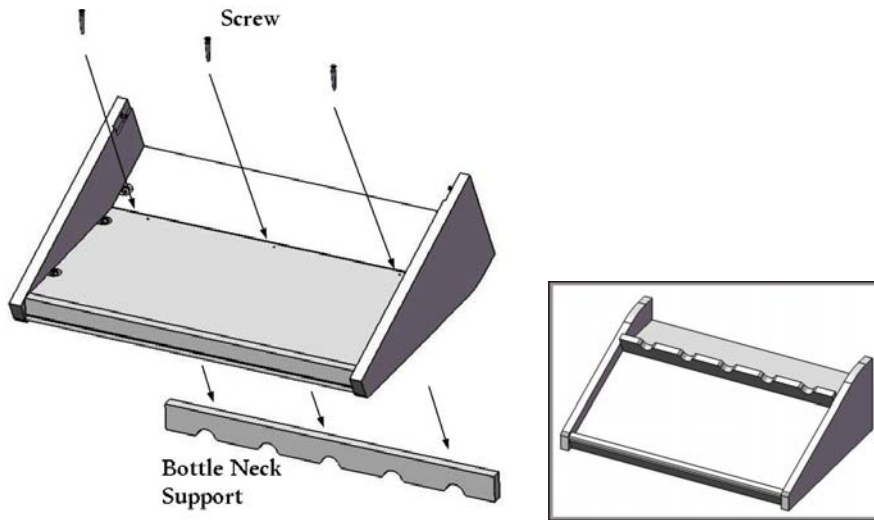

Flip the assembly over so the top is facing down. Pre-drill screw holes into the shelf base. Using the screws provided, drill through the holes on the bottom of the shelf base until the tip of the screw is showing. Line the bottle neck rest up with the screws and drill to attach.

Step 5

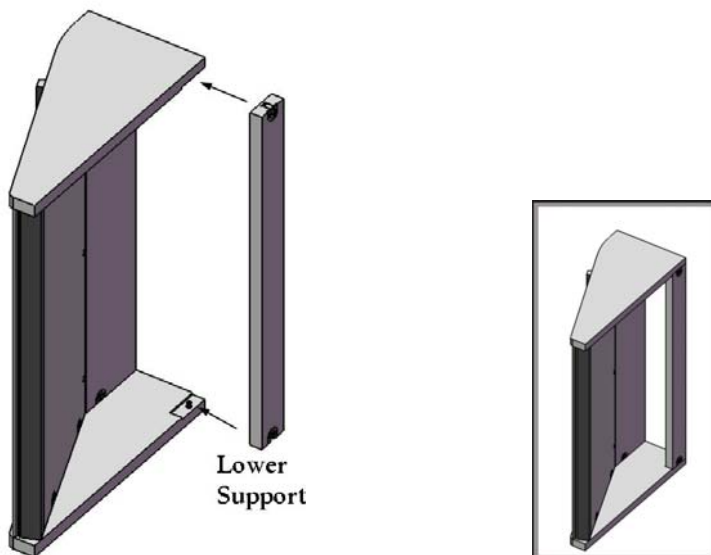

Turn the assembly back on its side and set your CAM fittings over the connector studs. Tighten all the CAM fittings around the connector studs.

Note: When attaching the retail message board, use the pre-drilled holes in the message board as your guide. Pre-drill through the holes provided and into the tabletop display. Then attach with the screws provided.

Additional installation questions?
Contact us:



VIGILANT, INC.
85 Industrial Park Drive
Dover, NH 03820
Toll Free 1-888-812-4427
Outside US 1-603-285-0400
Fax 1-603-285-0420
email: info@vigilantinc.com
On the web www.vigilantinc.com