



Commercial Wine Display Kits

Half Top Displays



Congratulations! You have purchased a superior commercial wine rack kit. These commercial kits have been specifically designed to properly store and display your wine. Please call toll free 888.812.4427 if you have any questions or problems.

Tools Required:

- Philips Head Screw Driver
- Power Drill
- 1/8" Drill Bit
- Counter Sink
- Mallet

Parts

- (1) Top Panel
- (1) Bottom Panel
- (1) Left Side Panel
- (1) Right Side Panel
- (1) Center Divider
- (1) Back Panel
- (6) #8 x 1 1/4" Square Head Screws
- (8) Connector Studs

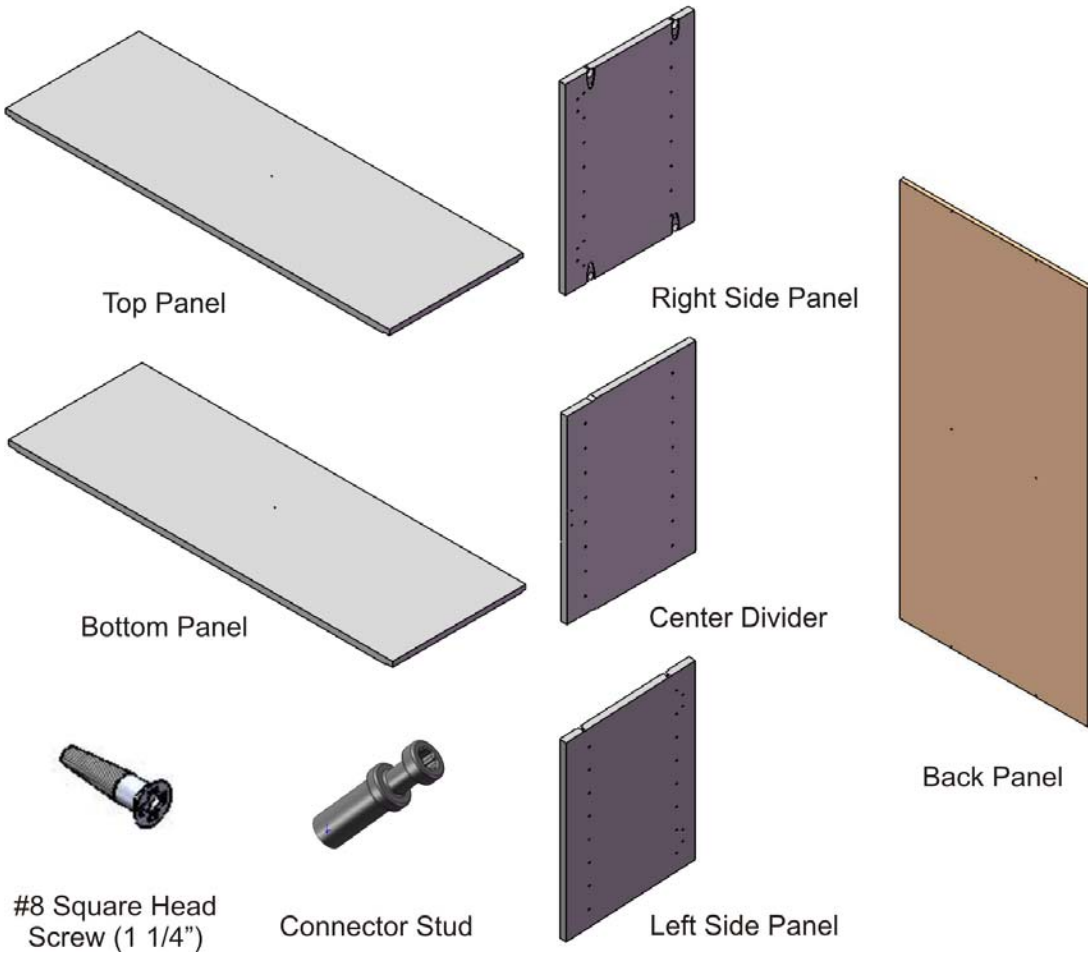

Parts List



Commercial Wine Rack Tips

Do not use a power drill when tightening your CAM fittings, if you do your CAM fitting could break.

Do not over tighten your CAM fittings or the CAM fitting will break.

Before assembling your commercial wine storage unit place a blanket down. You want a clean and scratch free surface during assembly.

Pre-drill all screw holes with a 1/8" drill bit. This makes it less likely for your wood to split. (The easiest way to do this is to follow the pre-drilled holes provided on certain pieces as your guide.)

If you are assembling a quarter round, **Do Not** pre-drill your screws holes for the toe kick or you might drill through the bottom shelf.

When assembling your case work make sure that all front edges are flush to one another.

Exploded View

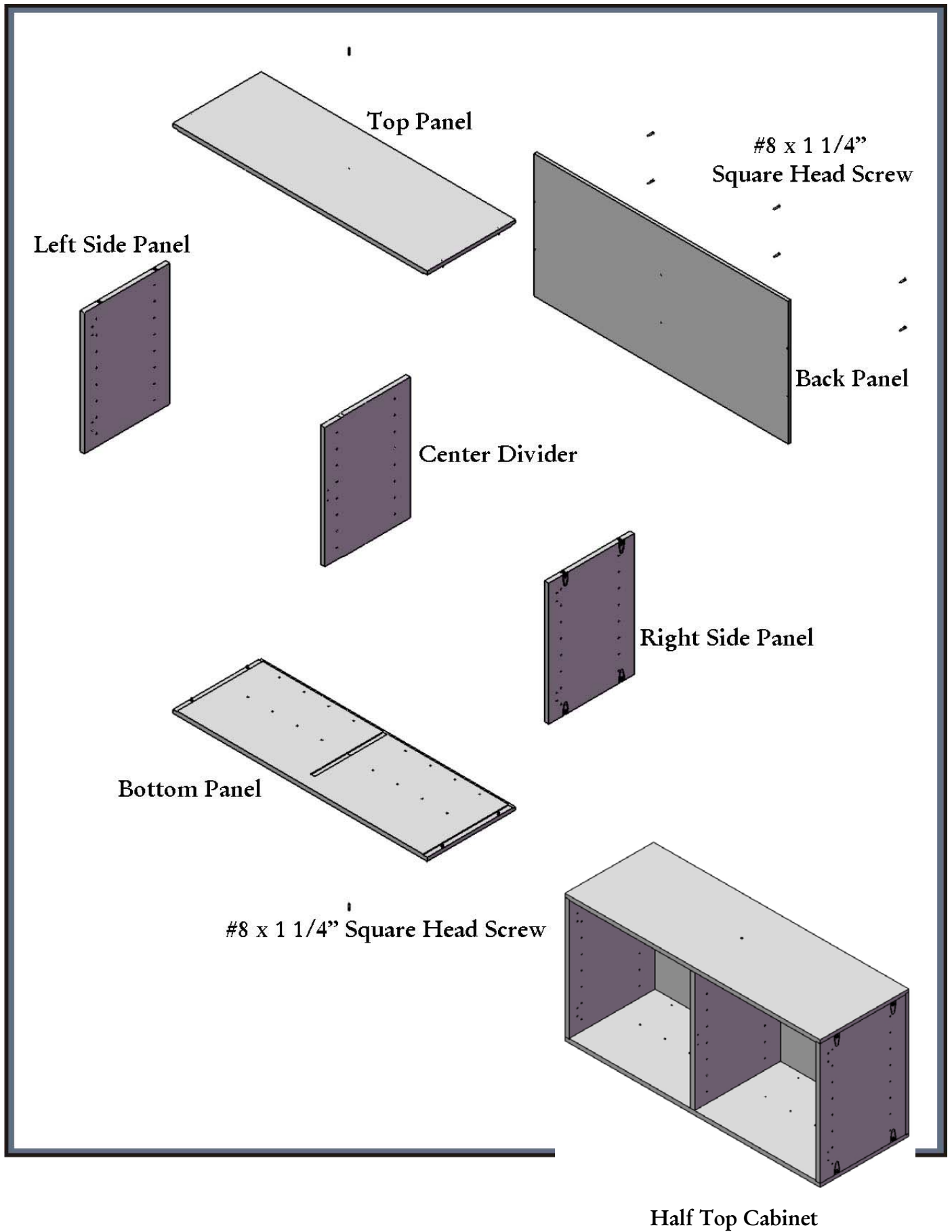

Steps to Assembly

Step 1

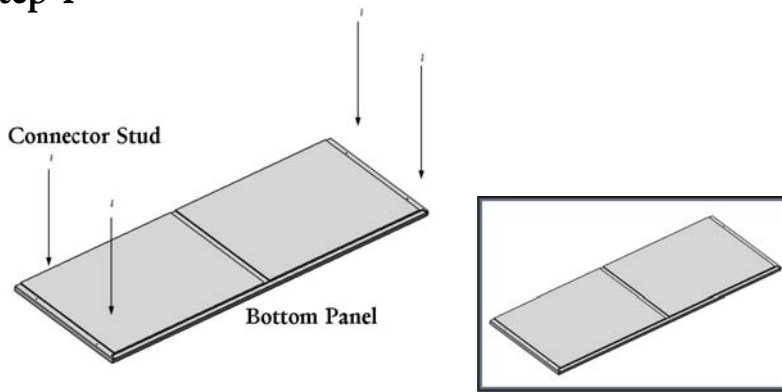

Find the 6 connector stud holes on the bottom and top panels and insert the connector studs.

Step 2

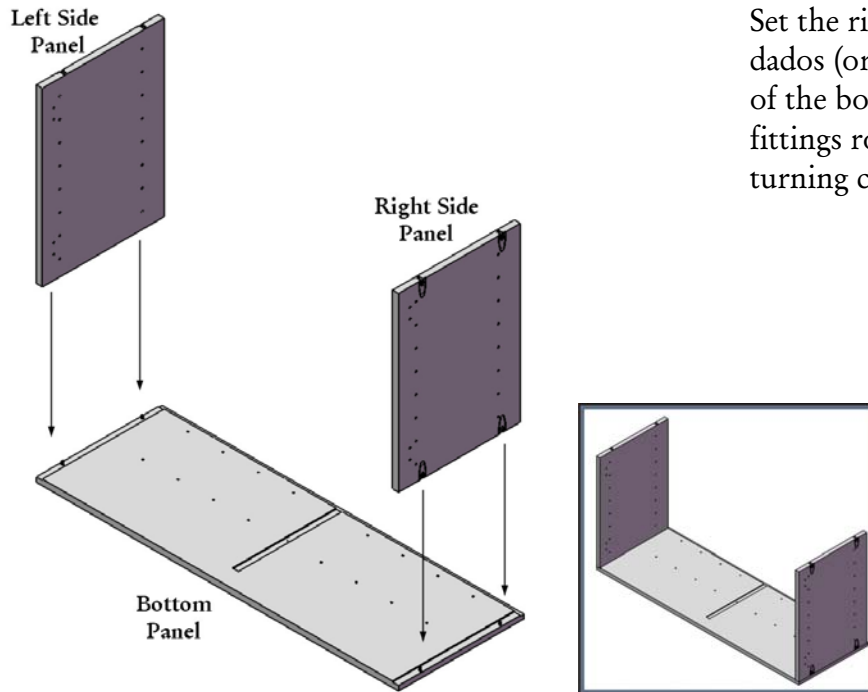

Set the right and left side panels into the dados (or grooves) on the right and left side of the bottom panel. Tighten the CAM fittings round the connector studs by turning clockwise 90 degrees.

Step 3

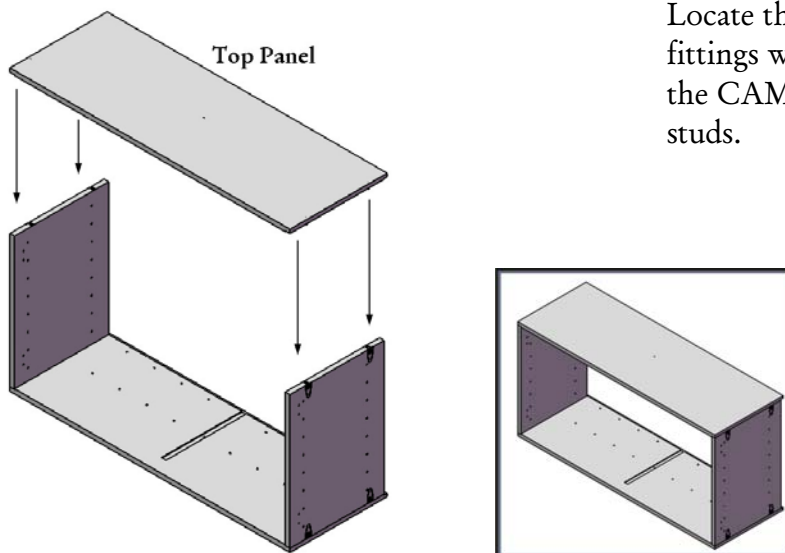

Locate the top panel, aligning the CAM fittings with the connector studs. Tighten all the CAM fittings around the connector studs.

Step 4

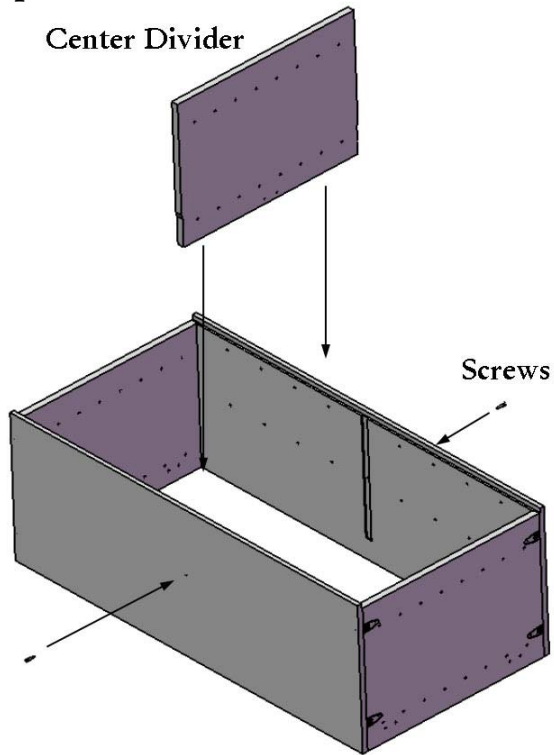

Flip the assembly so that the front of the cabinet faces the floor. Locate the center divider. Slide into the dado (or groove) on the top and bottom panels. Pre-drill and then attach using the 1 1/4" screws provided on the top and bottom of the cabinet.

Step 5

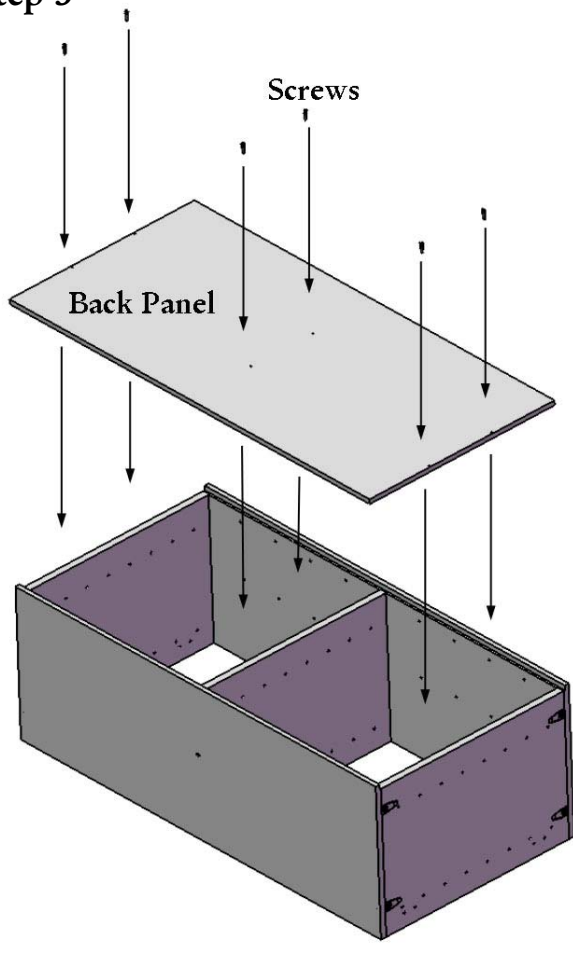

Locate the back panel. Slide in from the right or left side until the sides are flush. Using the existing holes on the back panels, pre-drill into the cabinet. Attach using 1 1/4" screws provided.

Optional Inserts (Shown with Single Base Display)

Half Diamond

*No Assembly Required

Parts:

(1) Half Diamond Panel

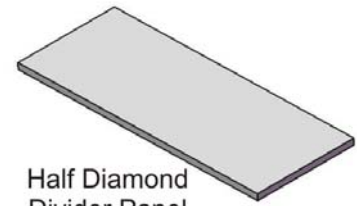

Step 1

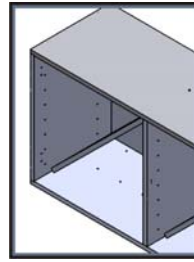
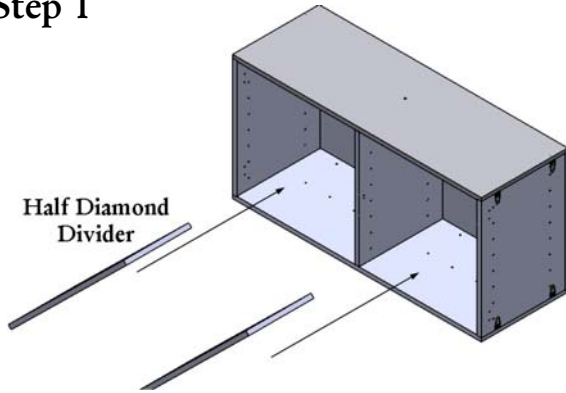

Angle the half diamond panel so that it slides into the cabinet from corner to corner. Make sure that the finished edge is flush and facing forward.

Diamond Divider

*No Assembly Required

Parts:

(1) Front Panel

(1) Back Panel

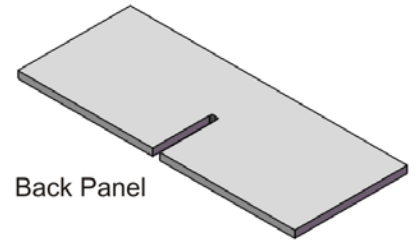
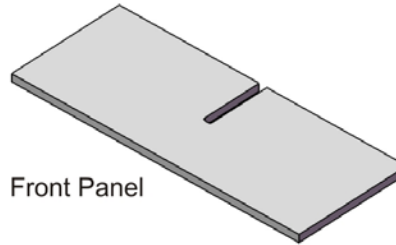

Step 1

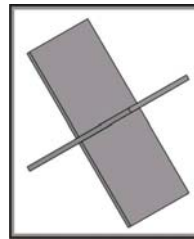
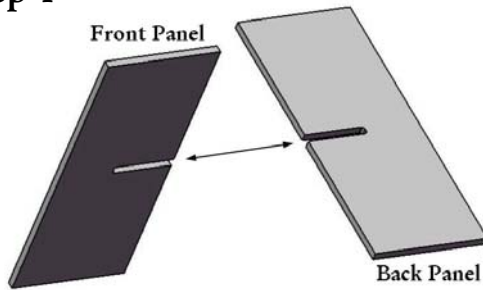

Insert front panel into the back panel at roughly a 45 degree angle. The slots on each panel should fit directly over each other. Make sure that the finished edges are flush and facing forward.

Step 2

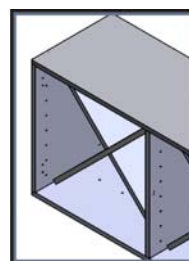
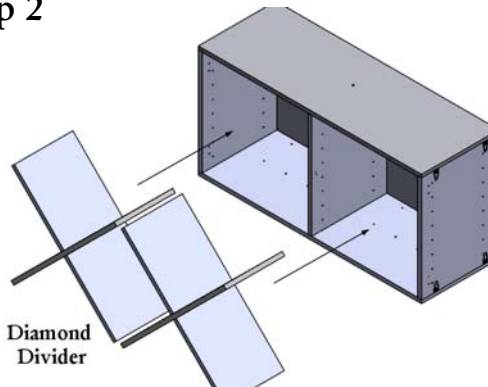

The diamond divider is now complete and can be inserted into the cabinet.

Display Shelf

Tools Required:

-Power Drill

-1/8" Drill Bit

Parts:

(1)Bottle Neck Rest

(3)#8 Square Head Screws

(1)Shelf Base

(4)Shelf Pins

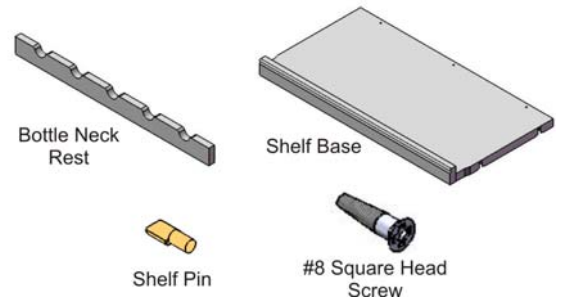

Step 1

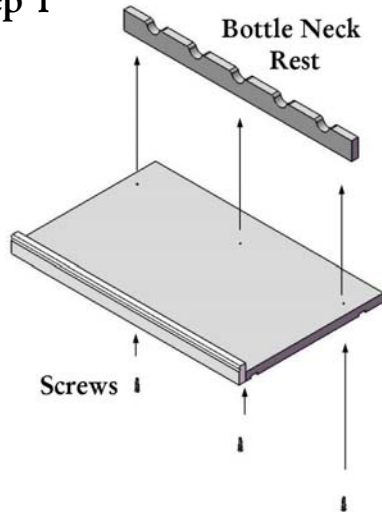

Pre-drill screw holes into the shelf base. Using the screws provided, drill through the holes on the bottom of the shelf base until the tip of the screw is showing. Line the bottle neck rest up with the screws and drill to attach.

Step 2

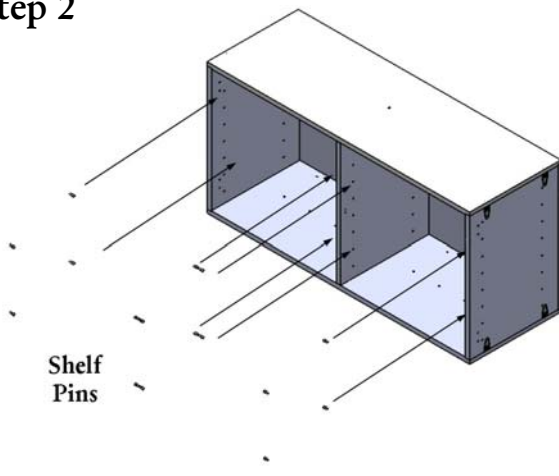

Insert the shelf pins provided into the cabinet to achieve desired shelf resting position.

Step 3

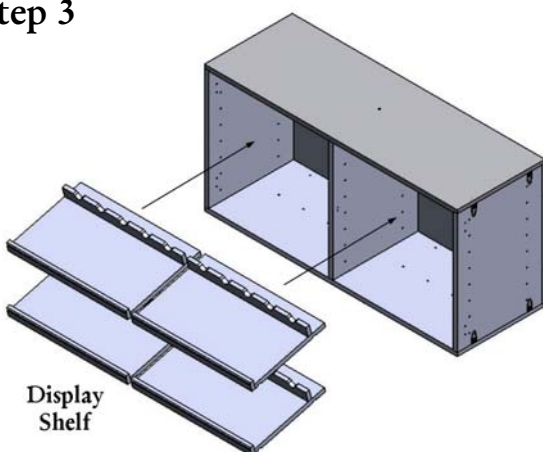

Insert the display shelves into the cabinet. (Display shelves can be inserted level or at a 20 degree angle.)

Flat Shelf

*No Assembly Required

Parts:

(1) Flat Shelf (4) Shelf Pins

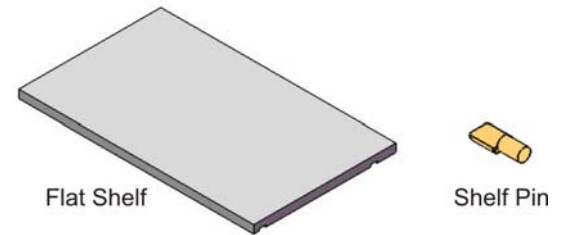

Step 1

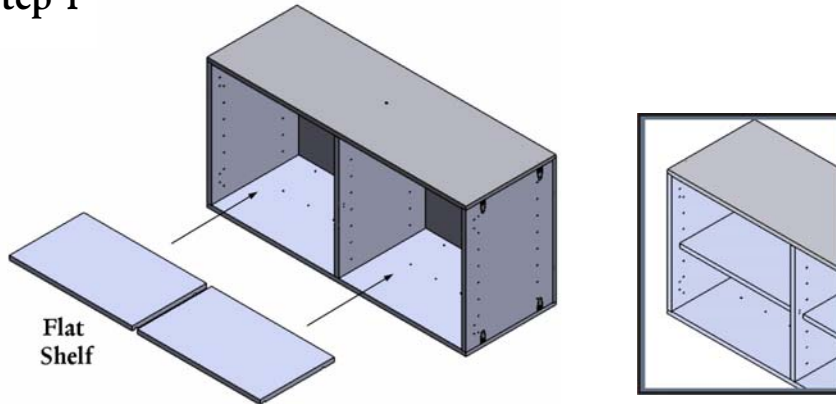

Insert shelf pins provided as done in Step 2 on page 7. Insert the flat shelf into the cabinet making sure it rests level.

Column Dividers

Parts:

(4) Column Dividers (16) Column Pins

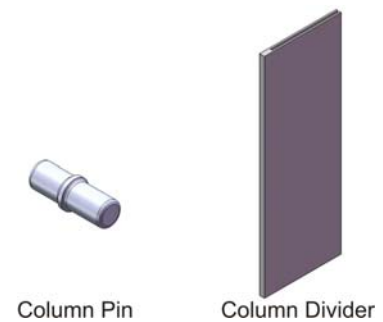

Step 1

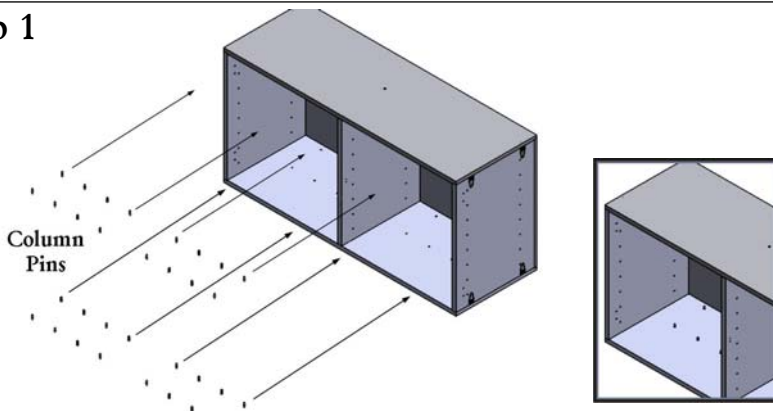

Insert column pins into the top and bottom of each shelf/panel of the cabinet.

Step 2

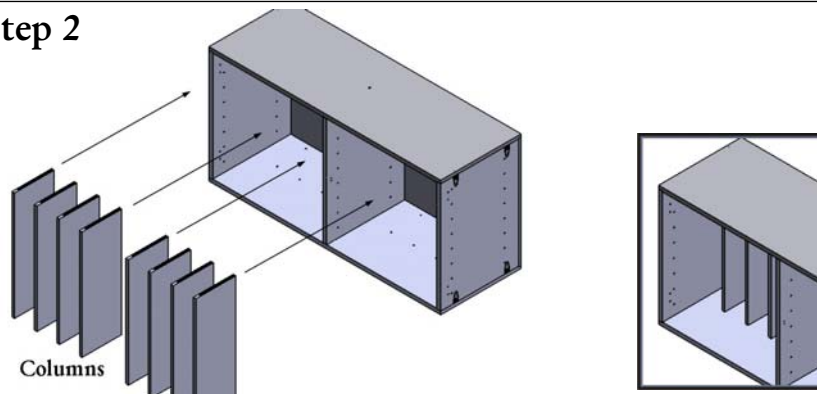

Line the dados, or grooves on the column dividers with the pins in the cabinet and slide into the cabinet.

Locker Doors

Parts:

(2)Doors (4)Hinges

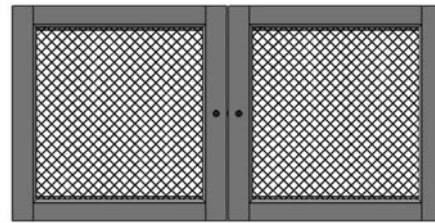

Locker Doors



Hinge

Step 1

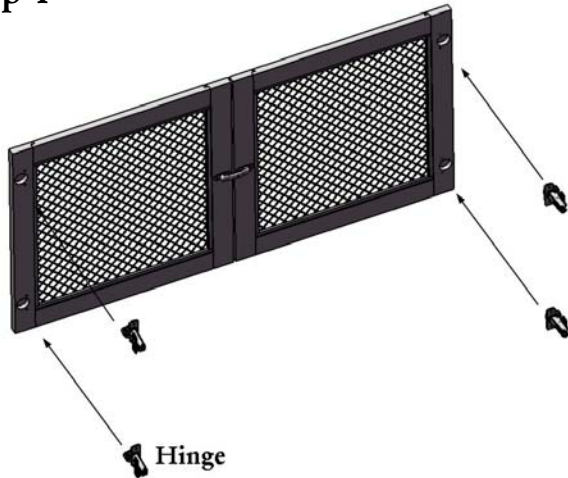

On a Scratch-free surface with the hinge holes facing up, take the first hinge with the rectangular cover plate open, press the round part of the hinge firmly into the holes.

Step 2

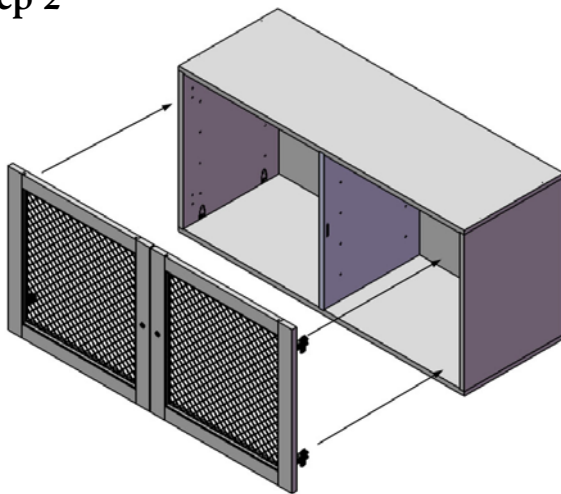

Standing the door upright, insert the two black pins on the hinge plate into the pre-drilled holes on the side panels of the cabinet. Make sure to press the plate firmly against the cabinet side and snap the levers closed.

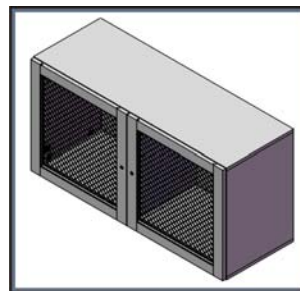

Hinge Adjustments

Hinge Adjustment

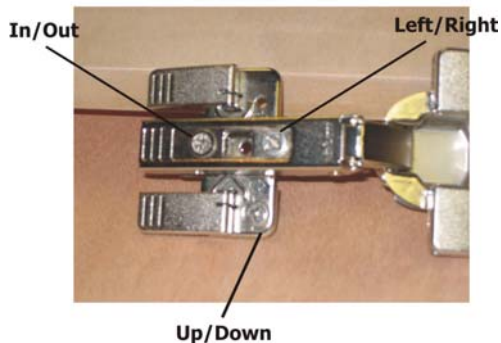

Moving the door up or down: Turn the adjustment screws on the hinge plate to bring the door up or down. Both screws must be adjusted.

Moving the door left or right: Turn the adjustment screw on the front of the hinge arm to move the door left or right. Both hinges may require this adjustment in order to get the door square to the cabinet.

Moving the door in or out: Turn the adjustment screw on the back of the hinge arm to move the door closer to the cabinet or further away. This may be required in order to get the door to land properly on the cabinet front.

Cubbie Insert

Parts:

(4) Back Panels (4) Front Panels

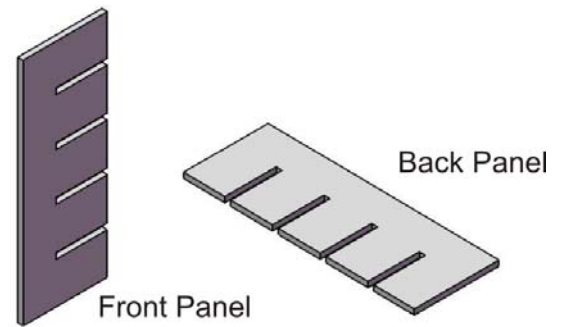

Step 1

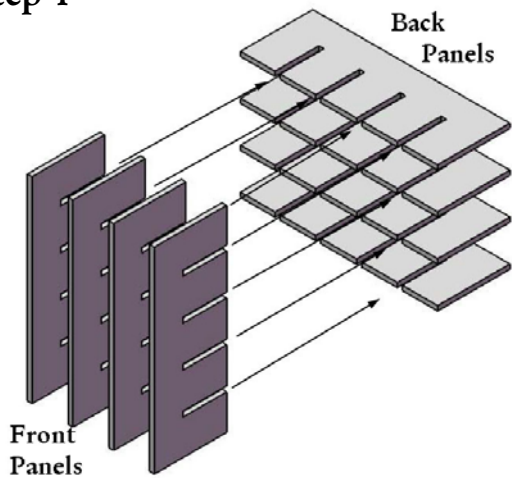

Slide (4) front panels over the slots on the (4) back panels. Making sure that the fronts of the vertical and horizontal panels rest flush to one another.

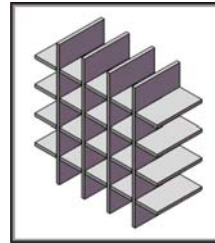

Step 2

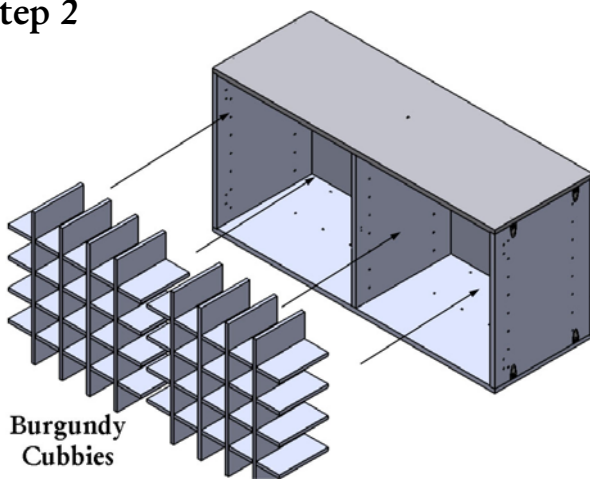

The cubbie insert is complete and can be inserted into the cabinet.

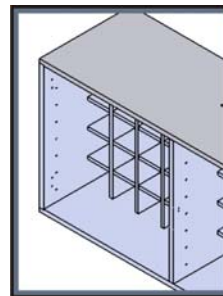

Additional installation questions?
Contact us:



VIGILANT, INC.
85 Industrial Park Drive
Dover, NH 03820
Toll Free 1-888-812-4427
Outside US 1-603-285-0400
Fax 1-603-285-0420
email: info@vigilantinc.com
On the web www.vigilantinc.com